

FRETURE

EMISSION FREE PROCESS

PROCESS AUTOMATION & CONTROL

INNOVATION FOR SUSTAINABILITY



CONTROL VALVE

www.freture.com

ISO 9001 - 15000 | ISO 14000 | ISO 45001 | PED 2014 / 68 / EU

Globe 2 Way Control Valve

Aspects of Performance and Design

- High rangeability and flow capacity
- Various trim choices Top opening for easy trim inspection without Affecting connections to pipes or connections
- Helpful direction for correct trim alignment in all operational situations
- Tight sealing for reliable handling even in the event of sudden or extreme shifts in temperature or pressure

Technical Specifications

DESIGN	: ASME B 16.34
VALVE SIZE	15 to 450 mm (1/2" to 18")
RATING	150 to 2500 ANSI
END CONNECTION	Flanged, Screw ed, Buttw eld, Socketw eld
MATERIAL	Carbon steel, Stainless steel, Monel, Duplex, Alloy 20, Hastelloy B/C, Aluminum Bronze, PP, Teflonlined etc.
BONNET	Standard from - 20°C to 250°C Normalizing betw een 250°C to 500°C Extended Bellow sealed
TRIM FORMS	Top guided Contoured. Splined Micro flow V- Ported (Balanced / Unbalanced) Low Noise (Upto four Stage Pressure Reduction Balanced / Unbalanced)
TRIM MATERIAL	Stainless steel, Alloy20, Monel, Duplex Hastelloy B/C, Stellite
FLOW CHAR.	Equal Percentage, Linear and Quick Opening
SEAT LEAKAGE	Class III, IV, V, & VI (FCI-70.2) Standard Leakage Rates Metal to Metal Seating Class 1V-less than 0.01% of rated Cv Metal to Soft Seating Class VI-Bubble tight (Zero Leakage)
GLAND PACKING	Grafoil or PTFE Chevron
ACTUATOR	Diaphragm, Piston or Electrical
ACTUATOR ACTION	Direct / Reverse Acting



Quality and performance assurance

The bellow seals for strong stem sealing which are available were Extensively developed and evaluated to ensure their optimum efficiency within the demanding parameters of the process specified. Several actuator choices can meet a majority of system requirements

Globe 3 Way Control Valve

Features of Design and Performance

- High rangeability and flow capacity
- Strong top guide with extra skirt guiding on the plug for added security.
- Strong, polished, and ground stem.
- Many interchangeable trim size options.
- Positive stem sealing is possible with the bellow seals.
- carefully planned and tested to ensure that it performs.
- the demanding process parameters mentioned.
- Many actuator satisfy the majority of system needs
- Every test was conducted in accordance with ASME 16.34 requirements.

DESIGN	: ASME B 16.34
BODY FORM	: Globe type with Tail piece to provide third port
VALVE SIZE	15 to 300 mm (1/2" to 12')
RATING	150 to
TRIM FORM	: Linear, V-Port Skirt Guided
FLOW CHAR.	: Linear, On/Off
SEAT LEAKAGE	: IV, V & VI (FCI-70.2)
ACTUATOR	: Diaphragm, Piston or Electrical
ACTUATOR ACTION	: Direct / Reverse Acting



Butterfly Control Valve (SERIES 200)

Features of Design and Performance



DESIGN	: Wafer (Complies to BS:5155)
VALVE SIZE	50 to 900 mm (T to 36")
BODY TYPE	: Metal to Metal / Sleeved / Teflon Seated
RATING	150 ANSI
FLOW CHAR.	: On-Off / Throttling
SEAT LEAKAGE	: II to VI (FCI-70.2)
MATERIAL	
BODY	: Cast Iron, Carbon Steel, Stainless Steel etc.
VANE	: Stainless steel, (Other on request)
BODY SLEEVE	: Neoprene, Nitrile, Teflon, EPDM etc.
GLAND PACKING	: PTFE V Ring upto 180°C Grafoil upto 400°C
ACTUATOR	: Diaphragm, Rotary or Electrical

- Small size, affordable, and low maintenance.
- Exceptional CV to size ratio.
- Dependable, seamless functioning and guaranteed product quality.
- Bubble-tight closure (class VI leakage). Rangeability 33 : I Throttling for modulating duty is used in the control range for the Off-SET (Teflon seated) / Centger Disc unction service

V-Noch Ball Control Valve (SERIES 300)

Features of Design and Performance

DESIGN	: Complies to BS:535 I
VALVE SIZE	15to300 mm(1/2"to IT)
BODY TYPE	: V-Notch / Full bore conventional
RATING	150 ANSI
FLOW CHAR.	: Throttling / On-Off
MATERIAL	
BODY	: Carbon Steel, Stainless Steel etc.
BALL	: Stainless Steel
SEAL	: Teflon, Viton
TEMPERATURE	180°C with PTFE Seal 250°C with Viton Seal
ACTUATOR	: Diaphragm, Rotary or Electrical



- Widely adjustable, turbulence-free flow through a full bore straight through structure.
- high ratio of CV to body size
- Class VI tight shut off leakage.
- Suitable for control action with a V-notch that is expertly shaped to produce a virtually equal percentage characteristic.

Diaphragm Control Valve (SERIES 400)

Features of Design and Performance

DESIGN	: Complies to BS:5 156
VALVE SIZE	15 mm to 200 mm (1 /2" to 8")
BODY TYPE	: Weir
END CONNECTION	125 ANSI
FLOW CHAR.	: On-Off /Throttling
BODY MATERIAL	: Cast Iron, Carbon Steel
LINING MATERIAL	: Ebonite, Neoprene, Teflon, EPDM, FRR Glass etc.
LINING THICKNESS	15 to 65mm Valve - 3mm
(Elastomer)	80 & 100mm Valve - 3.5mm
	125 & 150mm Valve - 4.0mm
	200mm Valve - 5mm
	PFA Lining - 3mm
	Glass Lining - 1.5mm
BODY DIA PHRAGM	: Neoprene, Teflon Backed with Neop Butyl, Nitrile, Hypalon, Viton, EPDM
ACTUATOR	: Diaphragm, Piston or Electrical
ACTUATOR ACTION	: Direct / Reverse acting



- Due to the greater area of the diaphragm exposed to line pressure, this is a low pressure type simple diaphragm valve.
- Weir design allows for perfect sealing and extended diaphragm life.
- Without any pockets, nooks, corners, grooves, or sharp edges, valves are self-cleaning.

Body Pressure Temperature Ratings

Table 1C- Cast Grade of Alloy Carbon Steel (ASTM A216 Gr. WC9)

Temperature		Working Pressures by Classes, PSIG / Kg/cm ² m											
0 _F	0 _C	150		300		400		600		900		1500	
		PSIG	Kg/cm ²	PSIG	Kg/cm ²	PSIG	Kg/cm ²	PSIG	Kg/cm ²	PSIG	Kg/cm ²	PSIG	Kg/cm ²
-20 to 100	-28.88 to 37.77	290	20.39	750	52.74	1000	70.32	1500	105.48	2250	158.22	3750	263.7
200	93.33	260	18.28	750	52.74	1000	70.32	1500	105.48	2250	158.22	3750	263.7
300	148.88	230	16.70	730	51.38	970	68.21	1445	101.60	2185	153.65	3640	255.9
400	204.44	200	14.06	705	49.57	940	66.10	1410	99.50	2115	148.20	3530	248.2
500	260.00	170	11.95	665	46.76	885	62.23	1330	93.63	1995	140.20	3325	233.8
600	315.55	140	9.84	605	42.54	805	56.61	1210	85.09	1815	127.63	3025	212.7
650	343.33	125	8.79	590	41.49	785	55.20	1175	82.03	1765	124.12	2940	206.7
700	371.11	110	7.73	570	40.03	755	53.09	1135	79.81	1705	119.90	2840	199.7
750	398.88	95	6.68	530	37.27	710	49.92	1065	74.89	1595	112.16	2660	187.0
800	426.66	80	5.62	510	35.86	675	47.46	1015	71.37	1525	107.24	2540	178.6
850	454.44	65	4.57	485	34.10	650	45.70	975	68.56	1460	102.67	2435	171.2
900	482.22	50	3.51	450	31.64	600	42.19	900	63.29	1350	94.93	2245	157.8
950	510.00	35	2.46	375	26.37	505	35.50	755	53.09	1130	79.46	1885	132.5
1000	537.77	20	1.40	260	18.78	345	24.26	520	36.56	780	54.85	1305	91.7

Table 1D- Cast Grade of Stainless Steel SS 316, SS 316L (ASTM A351CF8M, CF3M)

Temperature		Working Pressures by Classes, PSIG / Kg/cm ² m											
0 _F	0 _C	150		300		400		600		900		0	
		PSIG	Kg/cm ²	PSIG	Kg/cm ²	PSIG	Kg/cm ²	PSIG	Kg/cm ²	PSIG	Kg/cm ²	PSIG	Kg/cm ²
-20 to 100	-28.88 to 37.77	275	19.33	720	50.63	960	67.5	1440	101.2	2160	151.8	3600	253.16
200	93.33	235	16.52	620	43.60	825	58.00	1240	87.20	1860	130.80	3095	217.6
300	148.88	215	15.11	560	39.33	745	52.39	1120	78.76	1680	118.14	2795	196.5
400	204.44	195	13.71	515	36.12	685	41.18	1025	72.06	1540	108.20	2570	180.7
500	260.00	170	11.95	480	33.75	635	44.65	955	67.50	1435	100.90	2390	168.0
600	315.55	140	9.84	450	31.64	600	42.19	900	63.29	1355	95.28	2250	158.5
650	343.33	125	8.79	445	31.29	590	41.49	890	62.68	1330	93.53	2220	156.1
700	371.11	110	7.73	430	30.23	580	40.78	870	61.18	1305	91.77	2170	152.6
750	398.88	95	6.68	425	29.83	570	40.08	855	60.12	1280	90.01	2135	150.0
800	426.66	80	5.62	420	29.53	565	39.72	845	59.42	1265	88.75	2110	148.3
850	454.44	65	4.57	420	29.53	555	39.02	835	58.72	1255	88.20	2090	146.9
900	482.22	50	3.51	415	29.18	555	39.02	830	58.36	1245	87.50	2075	145.9
950	510.00	35	2.46	385	27.07	515	36.21	775	54.50	1160	51.57	1930	135.7
1000	537.77	20	1.40	350	24.61	465	32.70	700	49.22	1050	73.80	1750	123.0

Body Pressure Temperature Ratings

Table 1A- Cast Grade of Carbon Steel (ASTM A216 Gr. WCB)

Temperature		Working Pressures by Classes, PSIG / Kg/cm ²											
0 _F	0 _C	150		300		400		600		900		1500	
		PSIG	Kg/cm ²	PSIG	Kg/cm ²	PSIG	Kg/cm ²	PSIG	Kg/cm ²	PSIG	Kg/cm ²	PSIG	Kg/cm ²
-20 to 100	-28.88 to 37.77	285	20.04	740	52.03	990	69.62	1480	104.0	2220	156.1	3705	260.54
200	93.33	260	18.28	675	47.46	900	63.29	1350	94.93	2025	142.4	3375	237.34
300	148.88	230	16.17	655	46.06	875	61.58	1315	92.47	1970	138.5	3280	230.6
400	204.44	200	14.06	635	44.65	845	59.22	1270	89.31	1900	133.6	3170	222.9
500	260.00	170	11.95	600	42.19	800	56.25	1200	84.38	1795	126.2	2995	210.6
600	315.55	140	9.84	550	38.67	730	51.33	1095	77.00	1640	115.3	2735	192.3
650	343.33	125	8.79	535	37.62	715	50.28	1075	75.59	1610	113.22	2685	188.81
700	371.11	110	7.73	535	37.62	710	49.92	1065	74.89	1600	112.51	2665	187.41
750	398.88	95	6.68	505	35.51	670	47.11	1010	71.02	1510	106.18	2520	177.21

Table 1B- Cast Grade of Alloy Carbon Steel (ASTM A216 Gr. WC6)

Temperature		Working Pressures by Classes, PSIG / Kg/cm ²											
0 _F	0 _C	150		300		400		600		900		1500	
		PSIG	Kg/cm ²	PSIG	Kg/cm ²	PSIG	Kg/cm ²	PSIG	Kg/cm ²	PSIG	Kg/cm ²	PSIG	Kg/cm ²
-20 to 100	-28.88 to 37.77	290	20.39	750	52.74	1000	70.32	1500	105.48	2250	158.22	3750	263.7
200	93.33	260	18.28	750	52.74	1000	70.32	1500	105.48	2250	158.22	3750	263.7
300	148.88	230	16.17	720	50.63	965	67.86	1445	101.60	2165	152.25	3610	253.8
400	204.44	200	14.06	695	48.87	925	65.04	1385	97.39	2080	146.29	3465	243.6
500	260.00	170	11.95	665	46.76	885	62.23	1330	93.53	1995	140.29	3325	233.8
600	315.55	140	9.84	605	42.54	805	56.61	1210	85.09	1815	127.63	3025	212.7
650	343.33	125	8.79	590	41.49	785	55.20	1175	82.63	1765	124.12	2940	206.7
700	371.11	110	7.73	570	40.08	755	53.09	1135	79.81	1705	119.90	2840	199.7
750	398.88	95	6.68	530	37.27	710	49.92	1065	74.89	1595	112.16	2660	187.0
800	426.66	80	5.62	510	35.36	675	47.46	1015	71.37	1525	107.24	2540	178.6
850	454.44	65	4.57	485	34.10	650	45.70	975	68.56	1460	102.67	2435	171.2
900	482.22	50	3.51	450	31.64	600	42.19	900	63.29	1350	94.93	2245	157.8
950	510.00	35	2.46	320	22.50	425	29.80	640	45.00	955	67.15	1595	112.1
1000	537.77	20	1.40	215	15.11	290	20.39	430	30.23	650	45.71	1080	75.9

Selection of Bonnet.

The material used to make bonnets is the same as that used to make bodies. The stuffing box construction used by fuse bonnets is a bolted flange design. The design of the packing box allows for the interchangeability of any packaging materials. Figures illustrate the range of bonnet options.

Types of Bonnets

1. Bonnet Standard

Temperatures between 0°C and 230°C are suitable for standard bonnets.

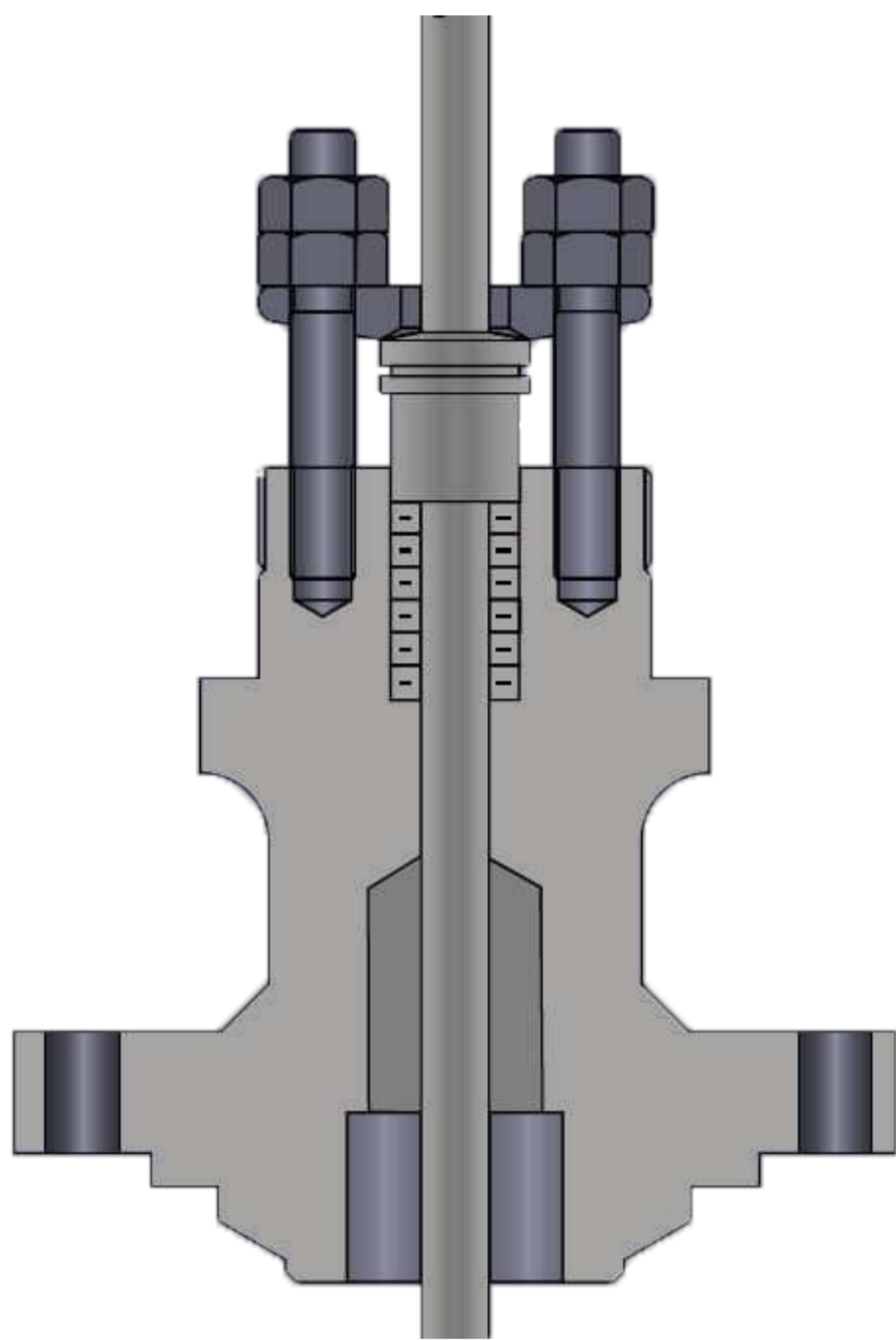

2. Extended Finned Bonnet

For high temperature service applications, ranging from +230 °C to 1000 °C, extended finned bonnets are utilized. 'Graphite gland packings' are included with these bonnets.

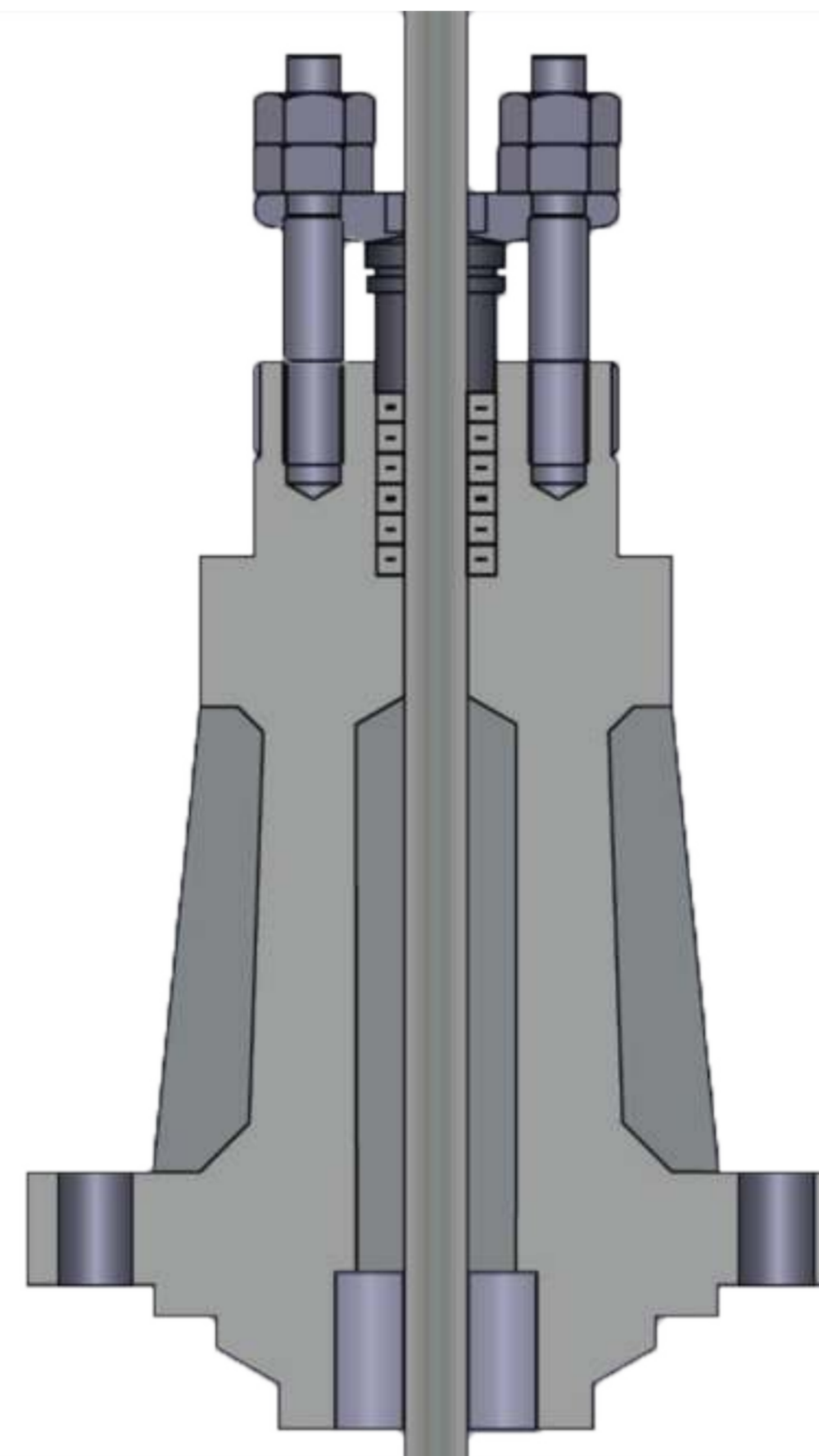

3. Extended Plain Bonnet

The service temperature range for extended plain bonnets is -100°C to 0°C.

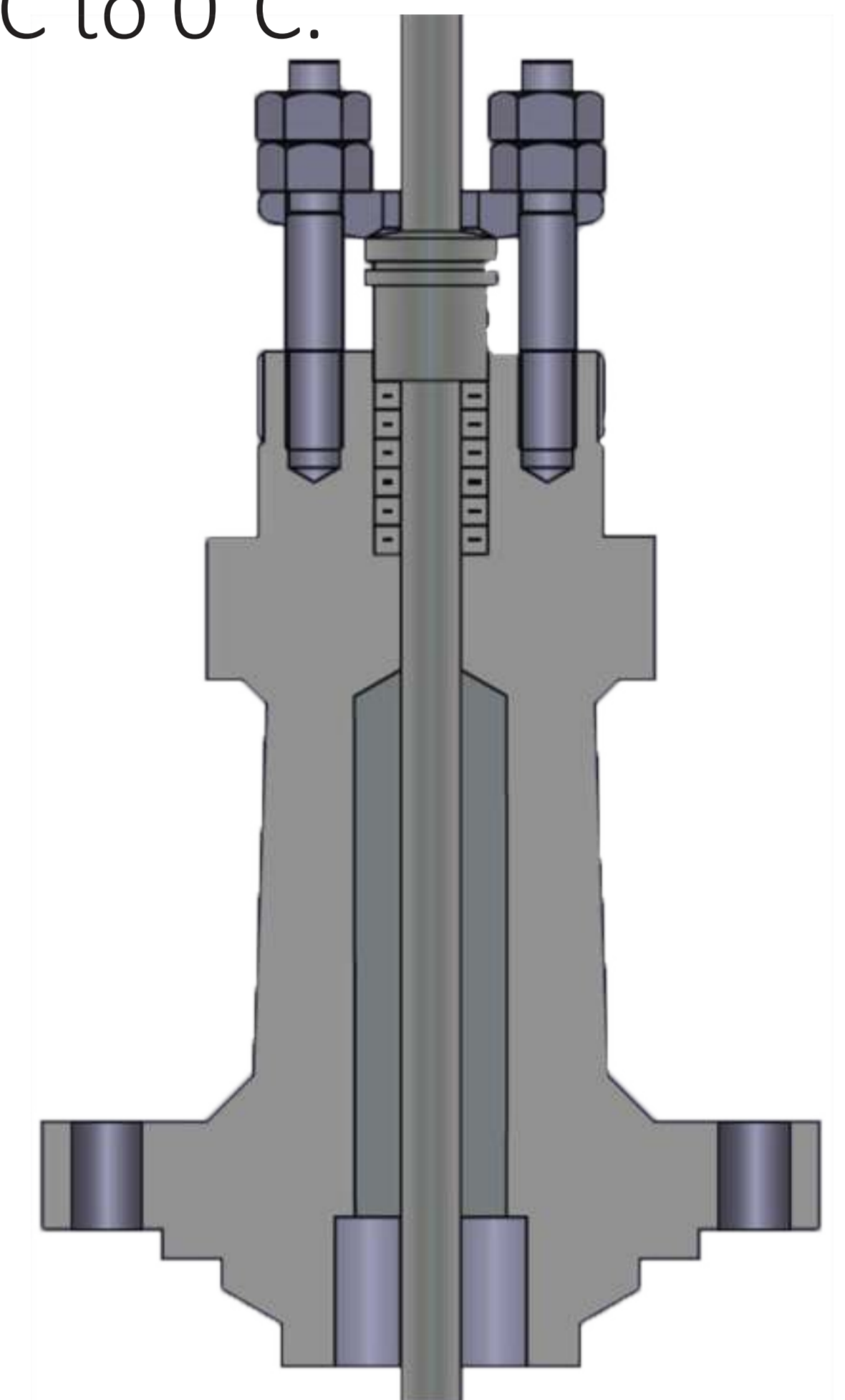

4. Cryogenic Bonnet

The bonnet's design allows for the least amount of heat transfer. The most common materials for bonnets are SS 304 or SS 316. The packing is shielded by the design from very low service temperatures (-100 to -198 °C).

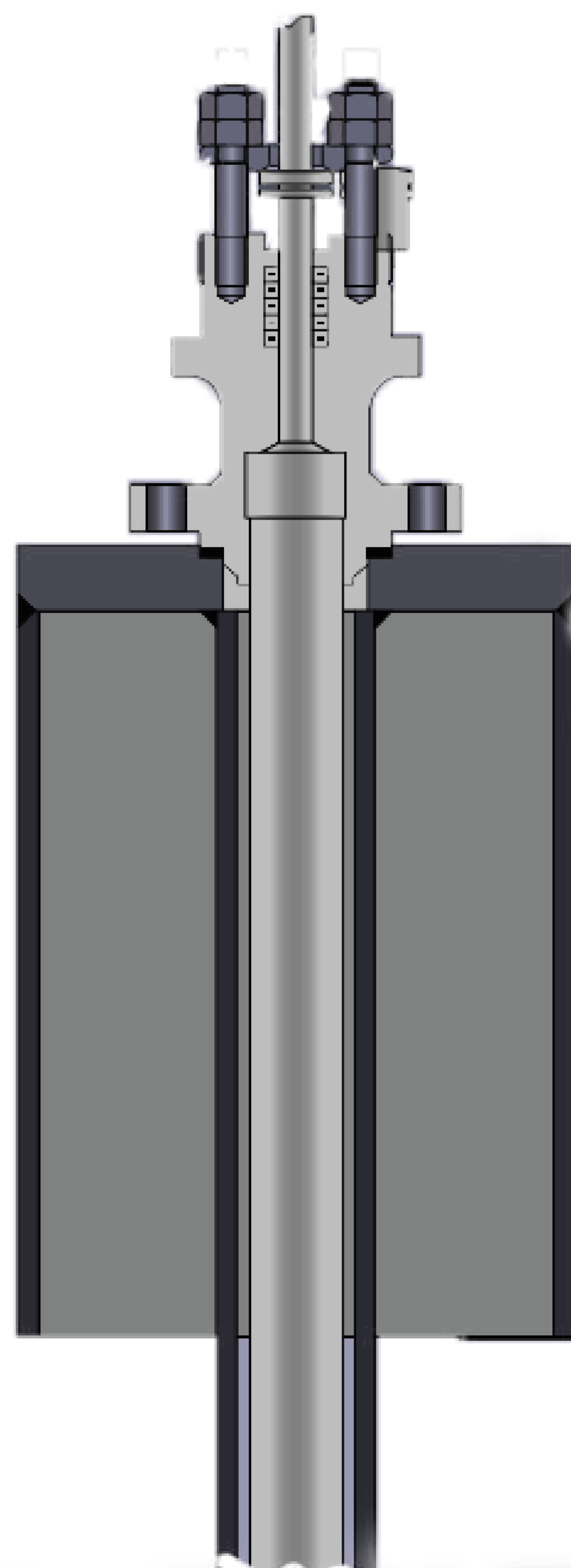

5. Bellows Sealed Bonnet

A bellows assembly was put in this type of bonnet to avoid leakage around the steam valve's plug. When there is zero tolerance for leakage around the valve stem, bellows sealed bonnets are utilized. Applications where the process fluid is hazardous, costly, flammable, or explosive are typical ones. SS 321 is a bellows material that can withstand pressure of as high as 45 kg/cm² and temperature up to 450 °F.

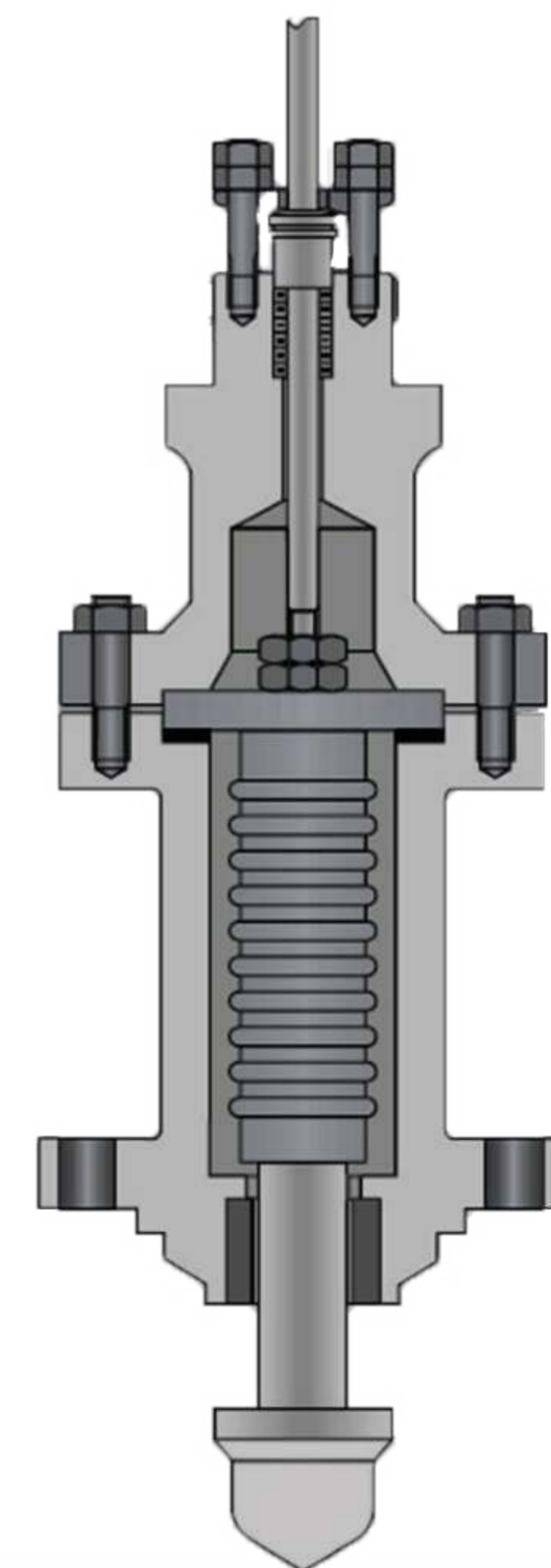

Selection of Gland Packing

Material	Working Pressure Limit (kg/cm)	Working Temperature Range (°C)
PTFE Impregnated asbestos	150	-250 to +200
PTFE Chevron (V-Rings)	100	-250 to +200
Graphite Moulded Rings	150	+200 to +600

Note: To further improve valve stem action and to reduce friction a silicone base moly-disulphide grease lubricant is recommended. It is suitable for use up to 260°C.

PRECAUTIONS: Packing should not be oiled for control valves in oxygen use because many lubricants, especially petroleum-based lubricants, are dangerous due to their rapid rate of reaction and heat of combustion.

Selection of Pressure Balance Seal Rings

Pressure Balance Seal Ring	Material	Temperature Limit (°C)
'U' Seal Ring	Graphite Filled P.T.F.E.	-100 to +200
Carbon Ring	Pure Carbon	+200 to +600
INMARCO Seal	Braided Jointless Graphite Ring	

Types of Bonnets

Type	Material	Working Pressure Limit (Kg/cm ²)	Working Temperature Range (°C)
Joint Sheet	Compressed Asbestos Fibre (CAF) with Inconel wire braided	40	-100 to +400
	P.T.F.E.	70	-250 to +200
Spiral Wound	PTFE Filler	100	-100 to +200
	SS 316/306 Strips	150	-250 to +200
Metal Flat Ring Type Serrated on both sides	Graphite Filler	100	-100 to +600
	SS 316, Inconel, Monel, Titanium, etc	150	-260 to +600

Selection of Body Studs

Body Material
Carbon Steel (Grade WCB)
Carbon Steel (Grade LCB)
Carbon Moly (Grade Wc1)
1¼ Cr - ½ Mo (Grade WC6)
2¼ Cr - 1Mo, (Grade WC9)
5 Cr - ½ Mo (Grade C5)
9 Cr - 1Mo (Grade C12)
Type 304 (Grade Cf8)
Type 347 (Grade CF8C)
Type 316 (Grade CF8M)
3½ Ni (Grade LC3)

Temperature	
°F	°C
-20 to 800	-29 to 427
-50 to 650	-46 to 344
-20 to 800 801 to 850	-29 to 427 428 to 455
-20 to 800 801 to 1000	-29 to 427 428 to 538
-20 to 800 801 to 1000 1001 to 1050	-29 to 427 428 to 538 539 to 566
-20 to 800 801 to 1000 1001 to 1100	-29 to 427 428 to 538 539 to 594
-20 to 800 801 to 1000 1001 to 1100	-29 to 427 428 to 538 539 to 594
-425 to 100 100 to 1500	-253 to 38 38 to 816
-425 to 100 100 to 1500	-253 to 38 38 to 816
-325 to 100 100 to 1500	-199 to 38 38 to 816
-150 to -50 -50 to 650	-102 to -46 -46 to 344

Stud Material as per ASTM	Nut Material as per ASTM
A193 Gr B7	A194 Gr 2H
A193 Gr B7	A194 Gr 2H
A193 Gr B7 A193 Gr B7	A194 Gr 2H A194 Gr 7
A193 Gr B7 A193 Gr B7	A194 Gr 2H A194 Gr 7
A193 Gr B7 A193 Gr B7 A193 Gr B16	A194 Gr 2H A194 Gr 7 A194 Gr 7
A193 Gr B7 A193 Gr B7 A193 Gr B16	A194 Gr 2H A194 Gr 7 A194 Gr 4
A193 Gr B7 A193 Gr B7 A193 Gr B16	A194 Gr 2H A194 Gr 7 A194 Gr 4
A320 Gr B8 A193 Gr B8	A194 Gr 8 A194 Gr 8
A320 Gr B8 A193 Gr B8	A194 Gr 8 A194 Gr 8
A320 Gr B8 A193 Gr B8M	A194 Gr 8 A194 Gr 8M
A320 Gr L7 A193 Gr B7	A194 Gr 4 W/Charpy Test or 8M A194 Gr 2H

Hardened/Hard Faced Trims

The edges are hardened or hardfaced to reduce galling between mating parts at high temperatures and to protect components like seat rings, plugs, guide bushings, and cages against erosion, abrasion, and cavitation. The fluid is gaseous or liquid, entrained solid particles in it, high flowing velocity, and its temperature are some of the factors that induce erosion of valve trim. The degree of metal part degradation

Various Trim Options

Contour

Because of its straightforward design, Contour Top Guided trims are the most popular option for a wide range of control applications. Maximum support is provided by a heavy top guide bush, which imparts total stability. The lower part of the bonnet was directed by the plug shank to reduce side thrust on the valve plug and minimize trim vibration.

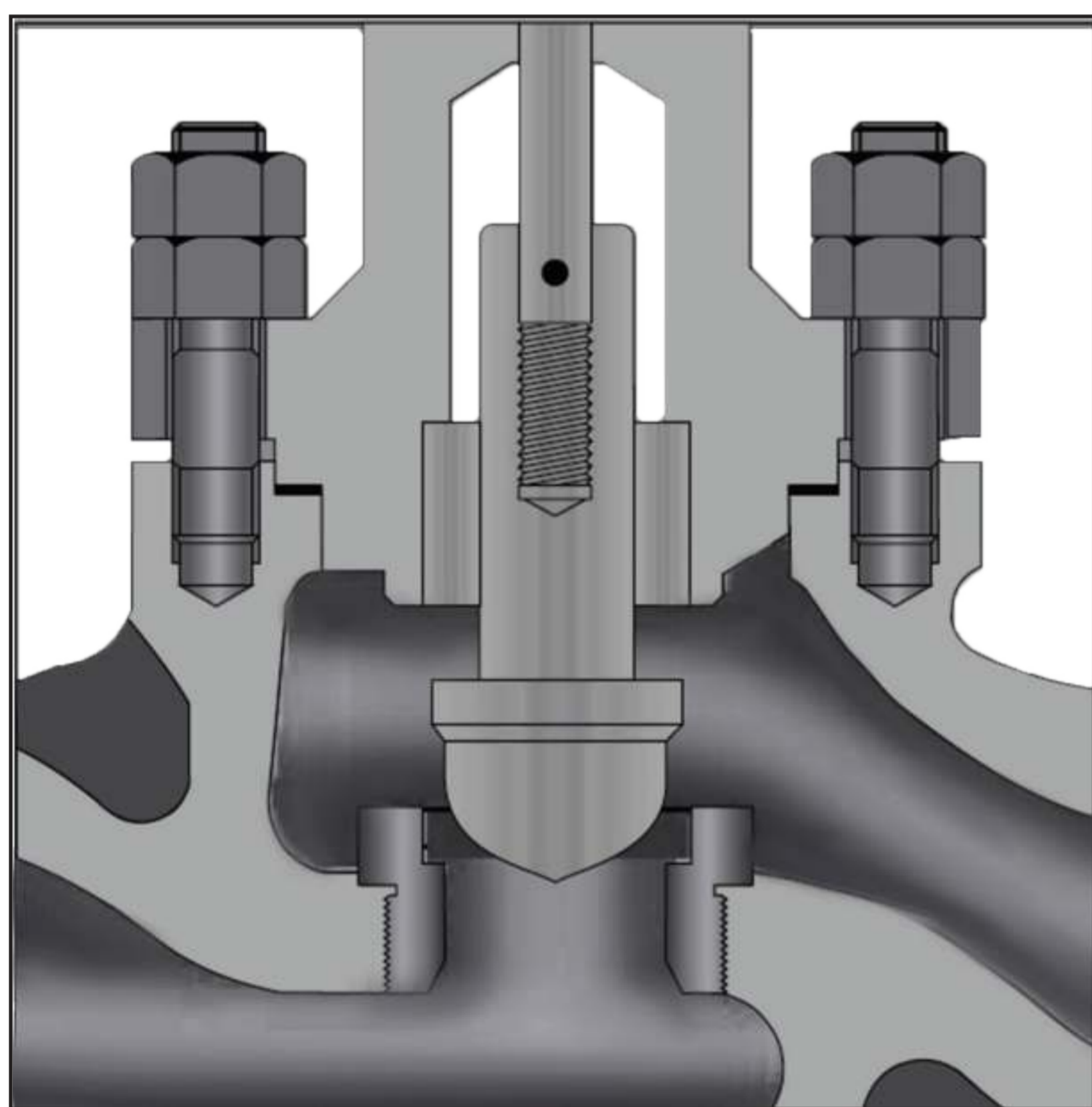

Cascade

The best trim option in situations with significant pressure drops and cavitation during throttling, which can lead to trim erosion, vibration, and noise. The image illustrates how the grooves in the plug reduce cavitation by dividing the large pressure drop into multiple stages.

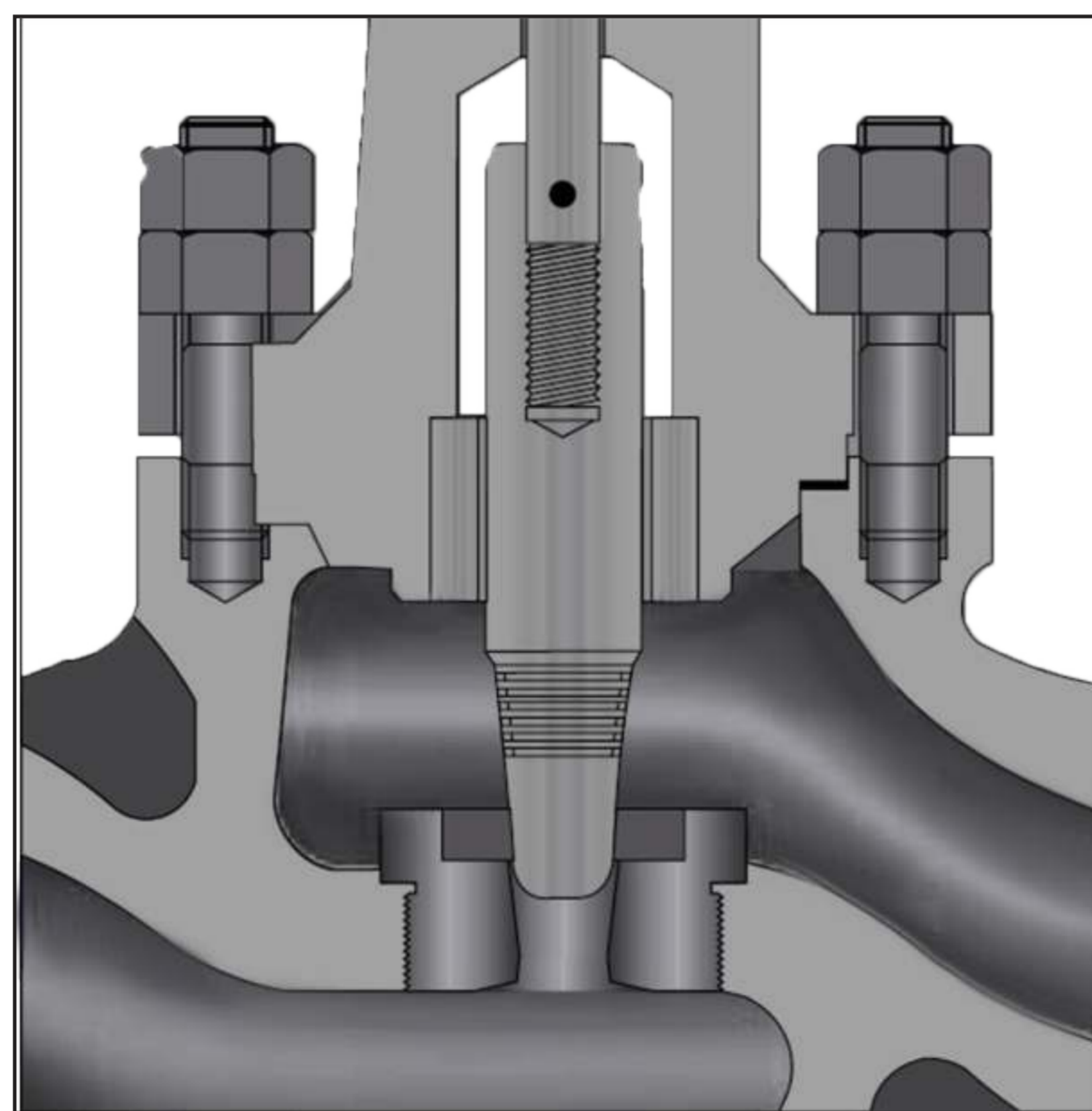

Micro

This trim is made to precisely manage minute flow rates and has an extremely high rangeability. To prevent nose breaking, the plug nose is carefully guided in the seat bore during valve travel in addition to its top guide. The actual seat bore is still 4mm in diameter, however the trims are designed at the alphabets A through M based on Cv values.

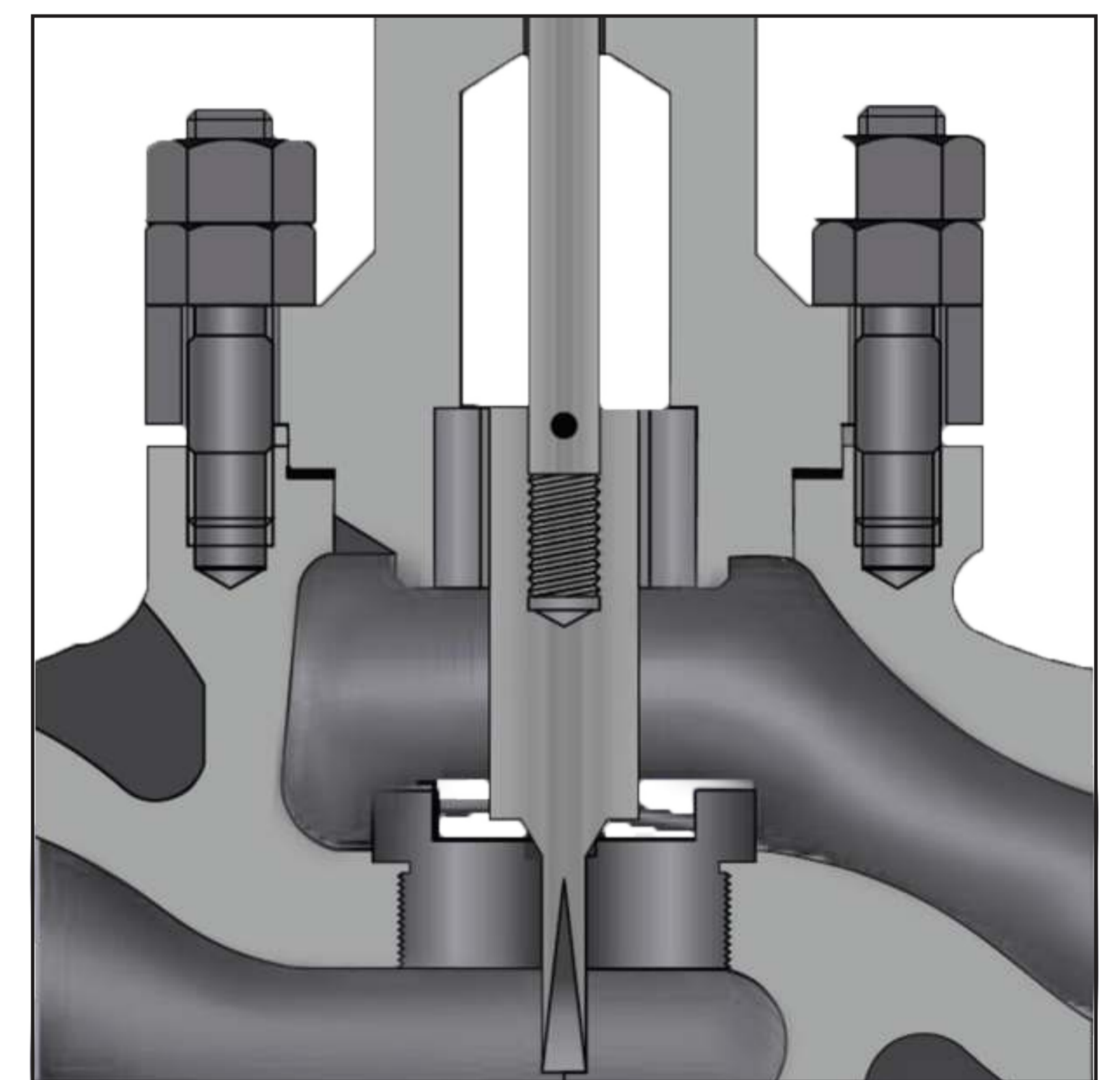

Disc(On-Off)

Disc trims are used in Quick Opening applications. These trims resemble contoured trims, however instead of having a parabolic contour, they are flat.

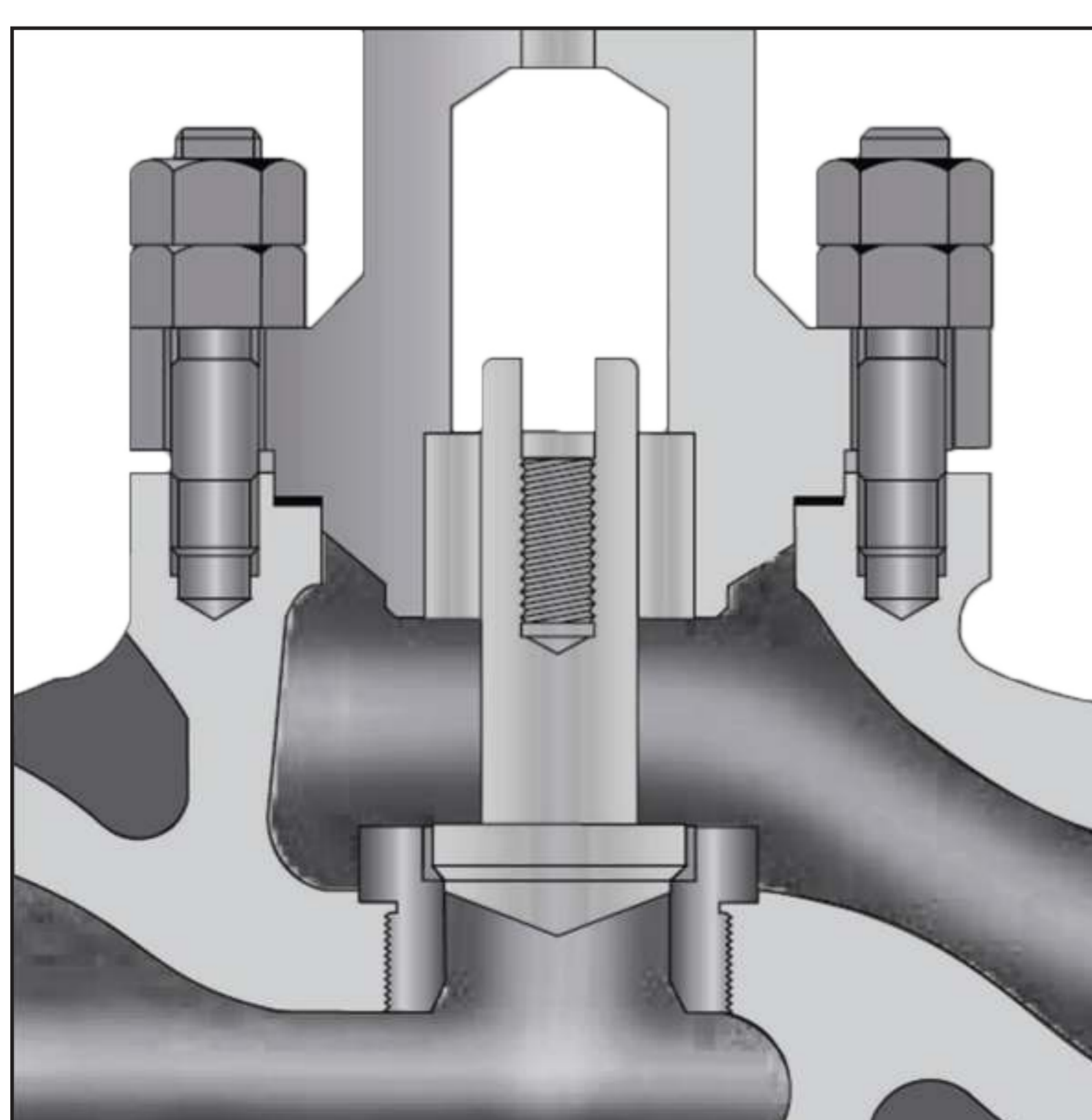

Trim With Soft Facing

The contour/disc type trims with glass filled P.T.F.E. or P.T.F.E. soft facing are used in tight shut off applications (Class VI per FCI 70-2) where the control valve must function as both a controlling and a shut-off valve. The readily replaceable P.T.F.E. soft facings are positioned between the shank and plug.

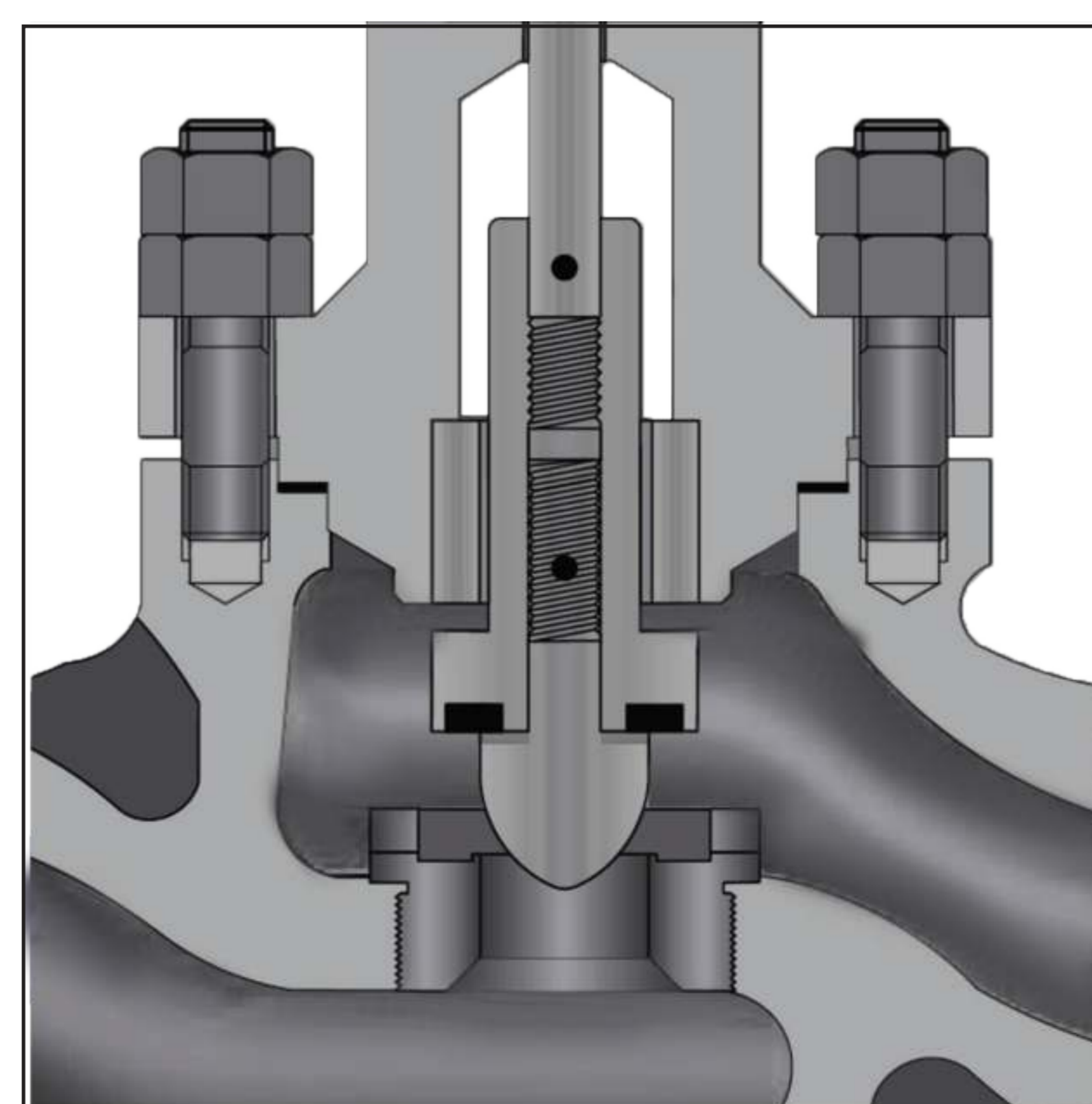

CV Values

Valve size		Trim Size		CV		Valve		Trim Size		CV
Inch	mm	Inc	mm	US		Inc	m			US
½, ¾ and 1	15, 20 and 25	1/8	3	1	½ ¾ 1	15 20 25	M	0.003		
		3/16	5	1.5			L	0.005		
		¼	6	2			K	0.0075		
		5/16	8	3			J	0.01		
		3/8	10	4			I	0.02		
								H	0.03	
1½	40	11/2	40	30			G	0.05		
		11/4	32	20			F	0.075		
		1	25	13			E	0.1		
2	50	2	50	50			D	0.15		
		11/2	40	30			C	0.2		
		11/4	32	20			B	0.3		
2½	65	21/2	65	80	A	0.4				
		2	50	50	1/32" (0.72mm)	0.5				
3	80	11/2	40	30	1/16" (1.6mm)	0.75				
			80	110						
		21/2	65	80						
4	100	2	50	50						
		4	100	200						
		3	80	110						
6	150	21/2	65	80						
		6	150	400						
		5	125	300						
8	200	4	100	200						
		8	200	640						
		6	150	400						
10	250	5	125	300						
		10	250	1000						
		8	200	640						
12	300	6	150	400						
		12	300	1350						
		10	250	1000						
14	350	8	200	2350						
		14	350	1800						
		12	300	1350						
16	400	10	250	2950						
		16	400	2350						
		14	350	1800						
18	450	12	300	1350						
		18	450	2950						
		16	400	2350						
20	500	20	500	3500						
		18	450	2950						

NOTE:

Typically, Cv values for the on-off flow characteristic will be 10% to 20% more.

If necessary, the previously mentioned Cv values for the linear flow characteristic might be raised by 10%.

Size 11/4 and smaller marked trims are invariably out of proportion.

CV Values

Valve size		Trim Size		CV
Inch	mm	Inch	mm	US GPM
1	25	1	25	12
		3/4	20	9
		1/2	15	5
1 1/2	40	1 1/2	40	27
		1 1/4	32	20
		1	25	13
2	50	2	50	45
		1 1/2	40	30
		1 1/4	32	20
2 1/2	65	2 1/2	65	72
		2	50	50
		1 1/2	40	30
3	80	3	80	100
		2 1/2	65	80
		50	50	50
4	100	4	100	180
		3	80	100
		2 1/2	65	80
6	150	6	150	360
		5	125	300
		4	100	200
8	200	8	200	580
		6	150	400
		5	125	300
10	250	10	250	900
		8	200	640
		6	150	400
12	300	12	300	1200
		10	250	1000
		8	200	640
14	350	14	350	1620
		12	300	1350
		10	250	1000
16	400	16	400	2100
		14	350	1800
		12	300	1350
18	450	18	450	2750
		16	400	2350
20	500	20	500	3100
		18	450	2950

Valve size		Trim Size		CV
Inch	mm	Inch	mm	US GPM
1	25	1	25	10
		3/4	20	7
		1/2	15	4
1 1/2	40	1 1/2	40	24
		1 1/4	32	16
		1	25	10
2	50	2	50	40
		1 1/2	40	24
		1 1/4	32	16
2 1/2	65	2 1/2	65	64
		2	50	40
		1 1/2	40	24
3	80	3	80	90
		2 1/2	65	64
		50	50	40
4	100	4	100	160
		3	80	90
		2 1/2	65	64
6	150	6	150	320
		5	125	240
		4	100	160
8	200	8	200	510
		6	150	320
		5	125	240
10	250	10	250	800
		8	200	510
		6	150	320
12	300	12	300	1100
		10	250	800
		8	200	510
14	350	14	350	1440
		12	300	1100
		10	250	800
16	400	16	400	1950
		14	350	1440
		12	300	1100
18	450	18	450	2360
		16	400	1950
20	500	20	500	2800
		18	450	2360



FRETURE TECHNO PVT. LTD.



Alpack Comp, Milind Nagar
Bhandup (W) Mumbai 400 078



www.freture.com



+91 75066 82777



sales@freture.com