

Freture offers a versatile range of 2, 3, and 5 Valve Instrument Manifolds, designed for safety, reliability, and leak-tight sealing in static and differential pressure applications. These manifolds provide easy block, bleed, and calibration of pressure transmitters, switches, and gauges. The 2 valve manifolds suit static pressure and liquid level applications, while the 3 and 5 valve models cater to differential pressure needs. Featuring stainless steel needle valves and PTFE gland packing, our manifolds ensure durability and operational integrity, with optional Grafoil packing for high-temperature uses. Available in direct and remote mount configurations, Freture's manifolds guarantee precision and performance.

## Materials of Construction

Component	Material
Handle	316 SS/A479
Set screw	316 SS/A479
Packing bolt	316 SS/A479
Packing nut	316 SS/A479
Upper gland	316 SS/A479
Jam nut	316 SS/A276
Lower gland	316 SS/A240 or A167
Packing	PTFE/D1710
Bonnet	316 SS/A479
Stem	316 SS/A276
Ball tip	316 SS/A479
Body	316 SS/A479
Stop pin	316 SS/A479
Lubricants	PTFE and tungsten disulfide

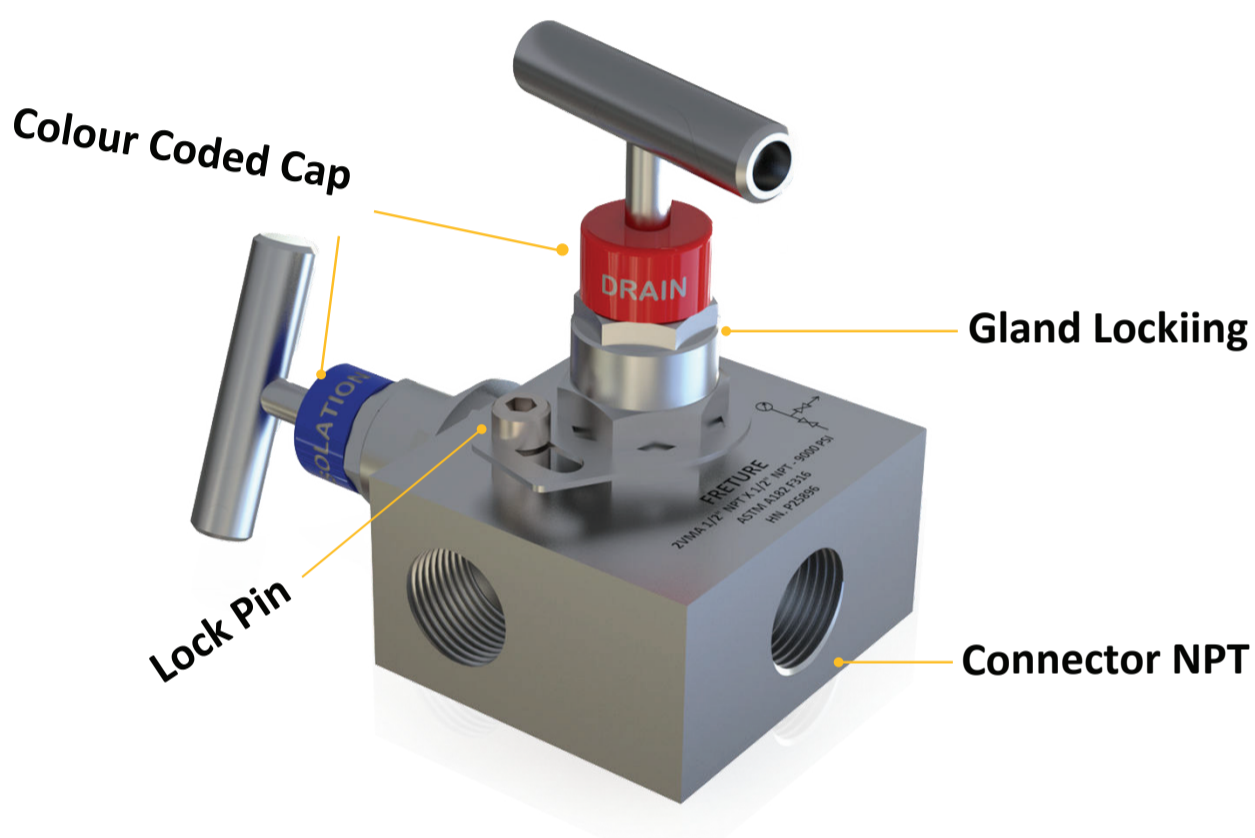

## Pressure-Temperature Ratings

Temperature	Working Pressure
-53°C to 38°C	413°C
93°C	355°C
121°C	338°C
148°C	321°C
176°C	307°C
204°C	294°C
232°C	284°C
260°C	274°C
287°C	266°C
315°C	259°C
343°C	254°C
371°C	248°C
398°C	242°C
426°C	238°C
454°C	232°C
482°C	225°C
510°C	221°C
537°C	208°C
565°C	206°C
593°C	184°C
621°C	157°C
648°C	118°C

## Technical Data

### Traditional Body Manifolds

Orifice Size ( With Isolation )	0.125" TO 0.156"
Weight	2-valve: 1 kg to 1.5 kg 3-valve: 1.5 kg to 3 kg 5-valve: 2.5 kg to 3.5 kg

### Compact Body Manifolds

Orifice Size	Vent valves—0.125 in Isolation valves—0.156 in
Weight	Block and bleed valves (1.2 to 1.4 kg) Double block and bleed valves (1.4 to 1.5 kg)

## 2 Valve Manifold - S Type

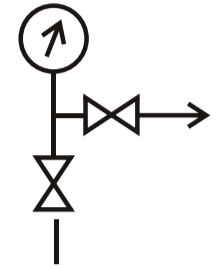
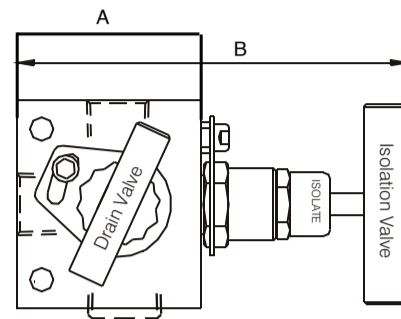
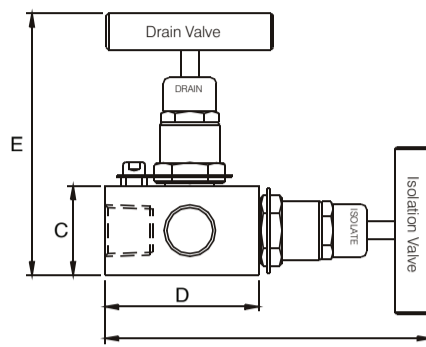

Pressure	Inlet	Outlet	Drain Port	A (mm)	B (mm)	C (mm)	D (mm)
6000	1/2" F	1/2" F	1/4" F	50.7	104.2	28.6	79.45

## 2 Valve Manifold - S2 Type

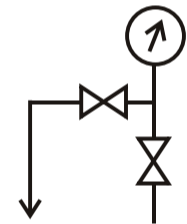
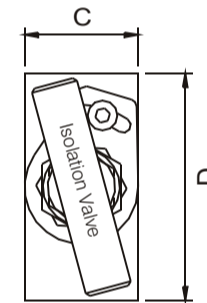
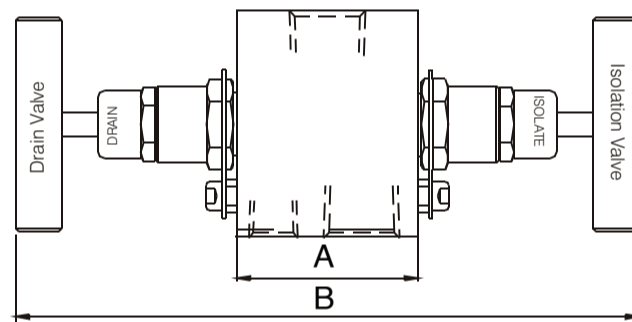
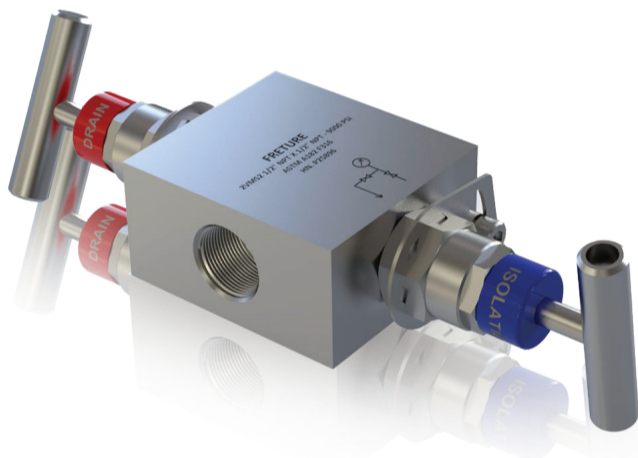

Pressure	Inlet	Outlet	Drain Port	A (mm)	B (mm)	C (mm)	D (mm)
6000	1/2" F	1/2" F	1/4" F	51.7	170.2	32.4	63.5

## 2 Valve Manifold - A Type

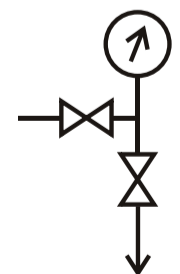
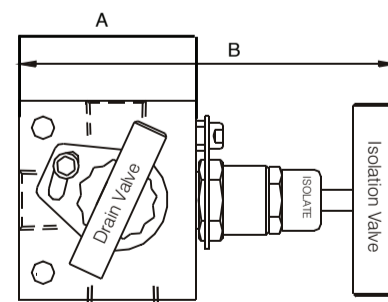
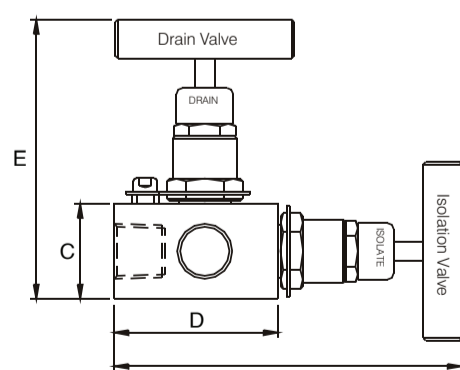

Pressure	Inlet	Outlet	Drain Port	A (mm)	B (mm)	C (mm)	D (mm)	E (mm)
6,000	1/2" F	1/2" F	1/4" F	50.8	100.5	28.6	63.5	79.4

## 2 Valve Manifold - E Type

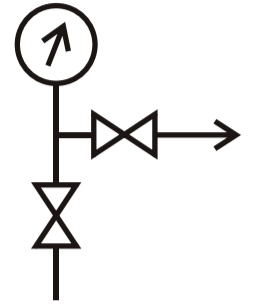
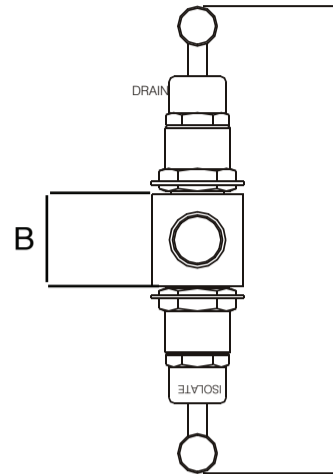
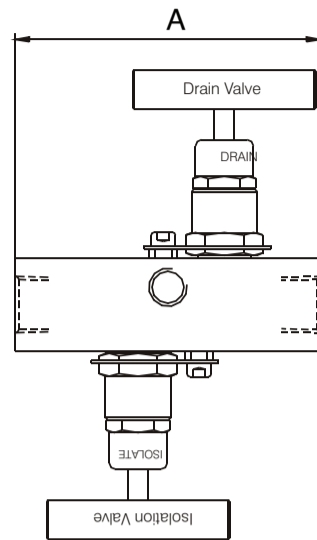
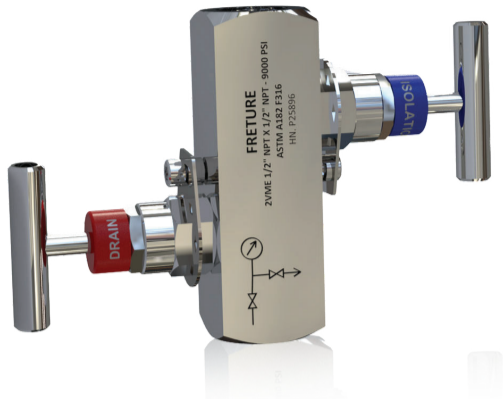

Pressure	Inlet	Outlet	Drain Port	A (mm)	B (mm)	C (mm)
6000	1/2" F	1/2" F	1/4" F	117.6	28.6	130.2

## 2 Valve Manifold - T Type

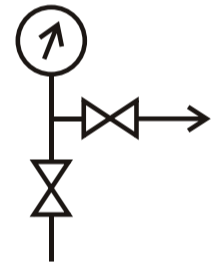
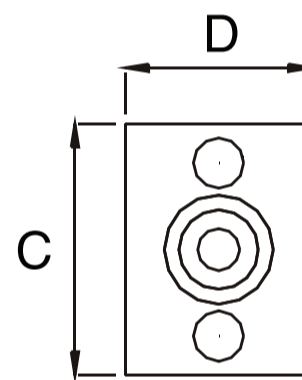
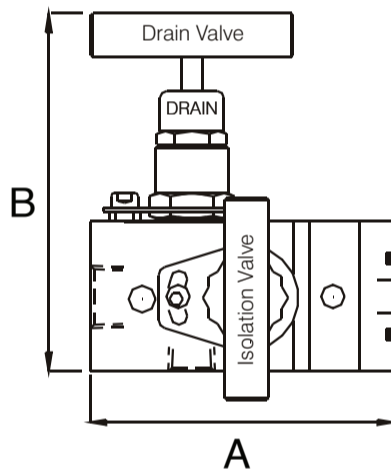
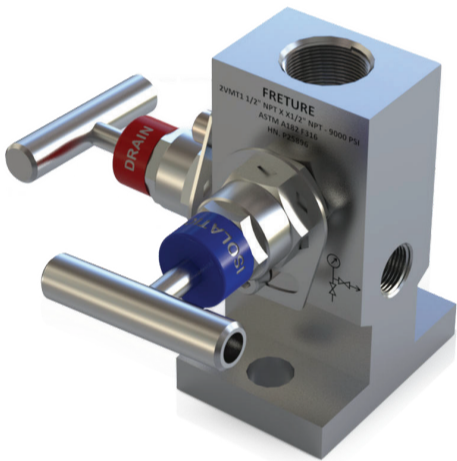

Pressure	Inlet	Outlet	Drain Port	A (mm)	B (mm)	C (mm)	D (mm)
6000	1/2" F	1/2" F	1/4" F	91	107.9	61.2	44.5

## 2 Valve Manifold Coplanar

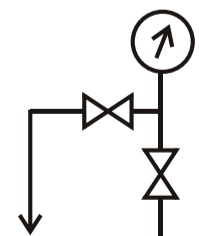
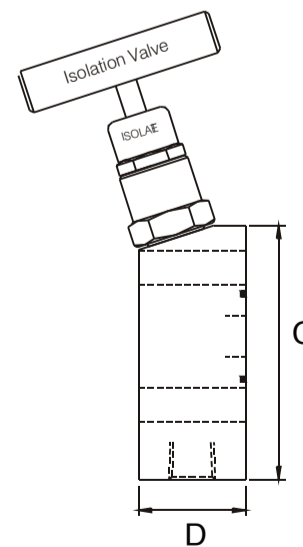
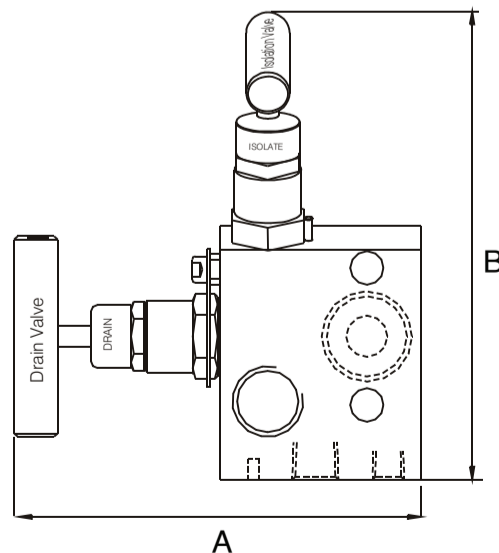

Pressure	Inlet	Outlet	Drain Port	A (mm)	B (mm)	C (mm)	D (mm)
6,000	1/2" F	1/2" F	1/4" F	124	135.8	75.7	32.24

## 3 Valve Manifold - S1 Type

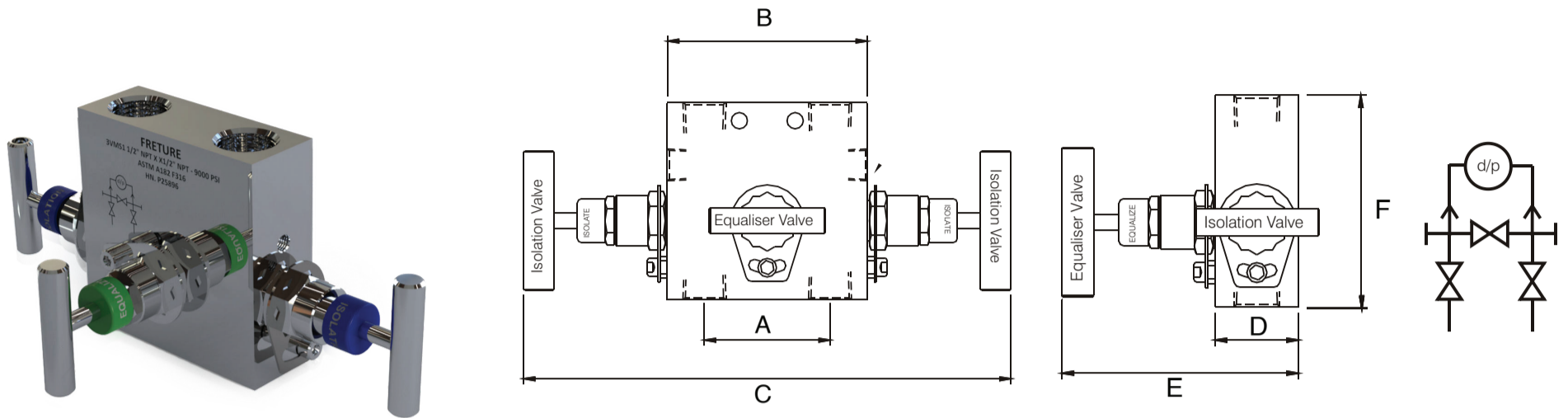

Pressure	Inlet	Outlet	A (mm)	B (mm)	C (mm)	D (mm)	E (mm)	F (mm)
Upto 10,000	1/2" F	1/2" F	54.5	102.3	215	27.5	84.2	57.5

## 3 Valve Manifold - S2 Type

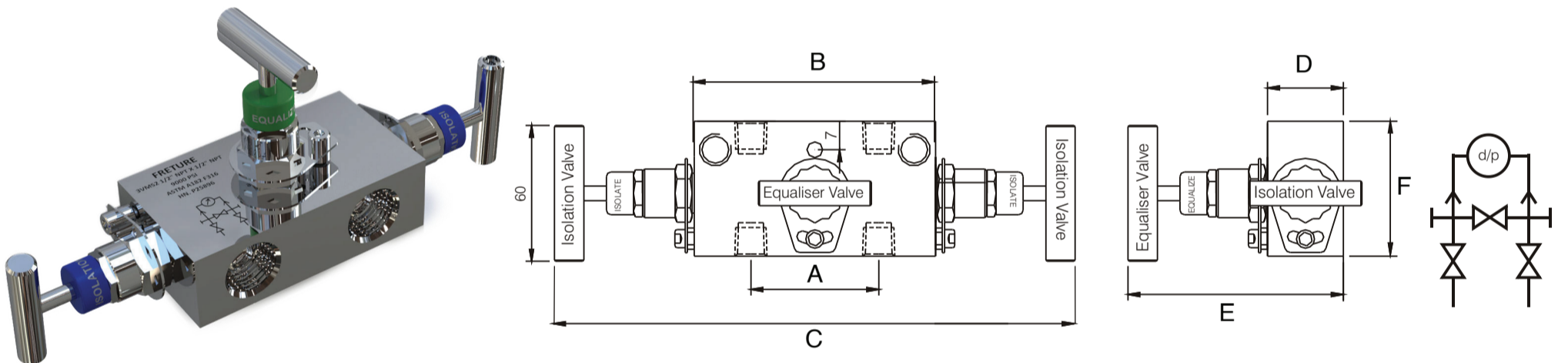

Pressure	Inlet	Outlet	A (mm)	B (mm)	C (mm)	D (mm)	E (mm)	F (mm)
Upto 10,000	1/2" F	1/2" F	54.5	102.3	215	27.5	84.2	57.5

## 3 Valve Manifold - T Type

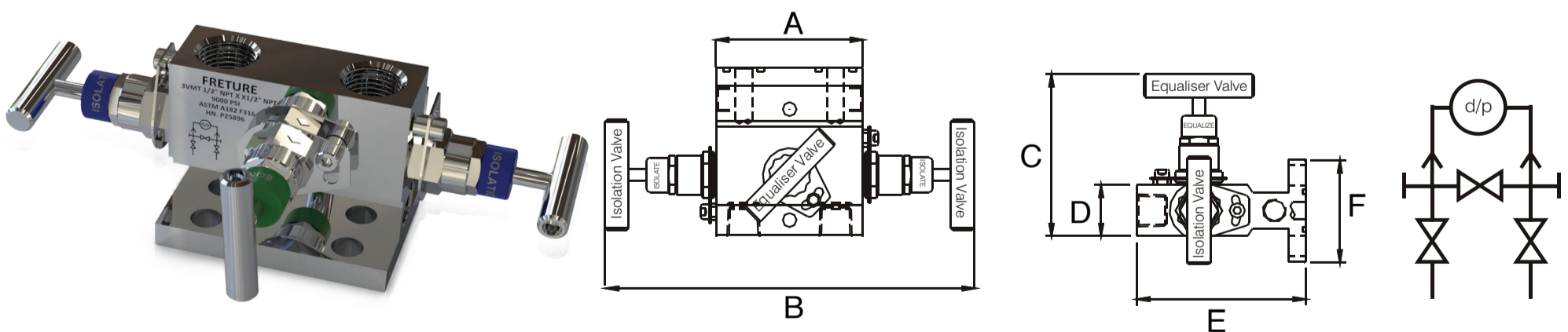

Pressure	Inlet	Outlet	A (mm)	B (mm)	C (mm)	D (mm)	E (mm)	F (mm)
6,000	1/2" F	1/2" F	88.3	212.4	95	32.42	77.2	58.5



## 3 Valve Manifold Coplanar

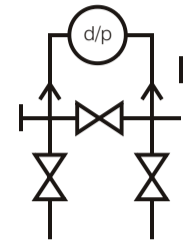
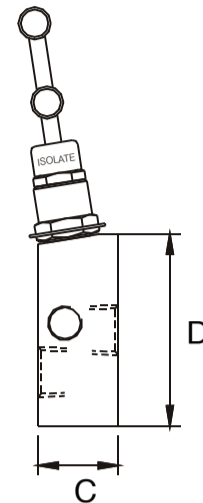
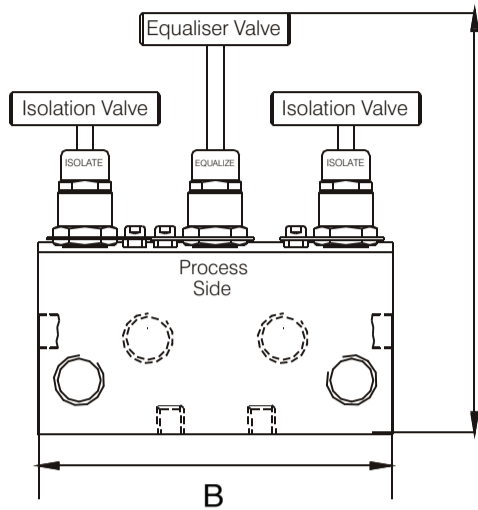
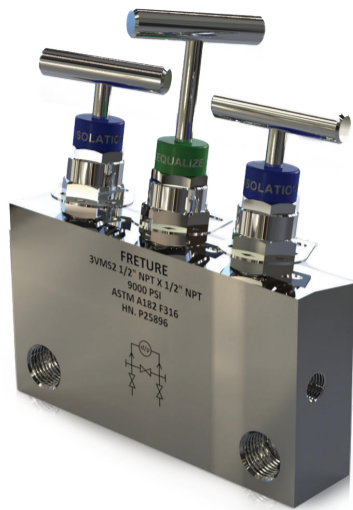

Pressure	Inlet	Outlet	Drain Port	A (mm)	B (mm)	C (mm)	D (mm)
6000	1/2" F	1/2" F	1/4" F	150.5	130.9	32.6	76.3

## 3 Valve manifold - H Type

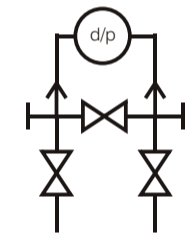
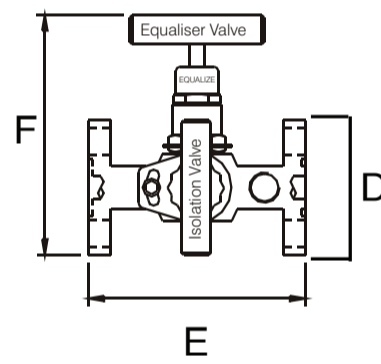
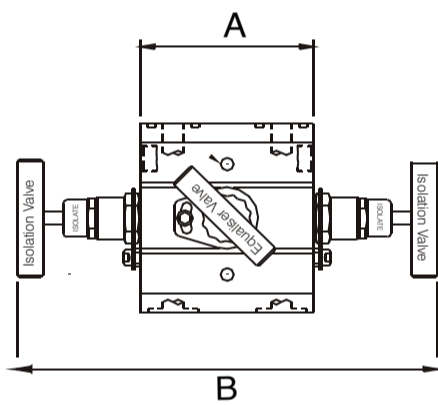
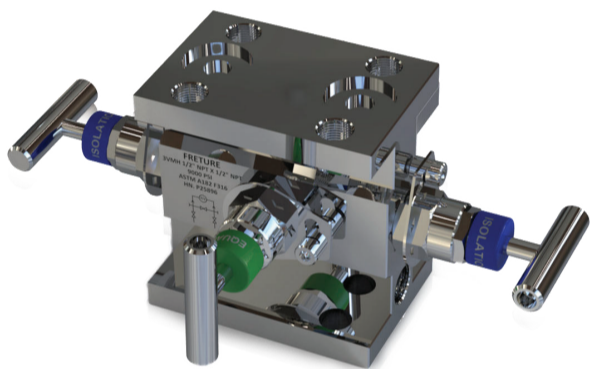

Pressure	Inlet	Outlet	A (mm)	B (mm)	C (mm)	D (mm)	E (mm)	F (mm)
6,000	1/2" F	1/2" F	90.95	200.2	31	62.2	97.45	98.2

## 5 Valve Manifold - T Type

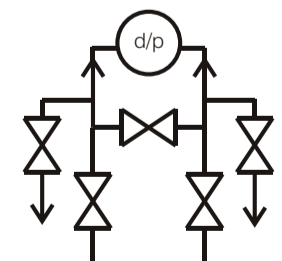
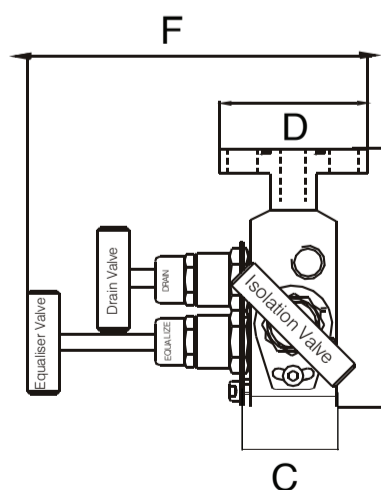
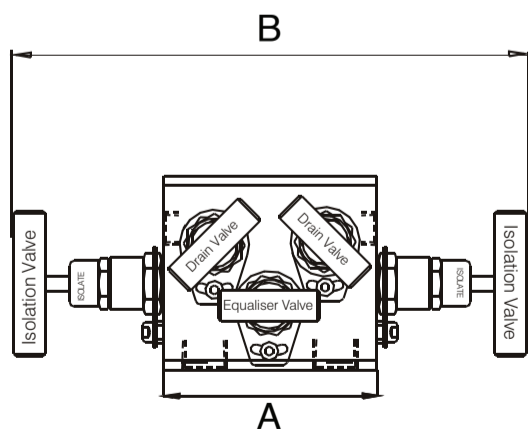
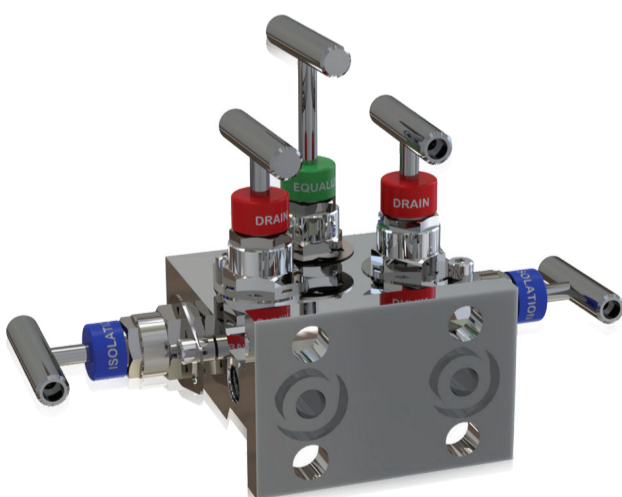

Pressure	Inlet	Outlet	Drain Port	A (mm)	B (mm)	C (mm)	D (mm)	E (mm)	F (mm)
6,000	1/2" F	1/2" F	1/4" F	91.2	210	35.4	62.5	109	116

## 5 Valve Manifold - S Type

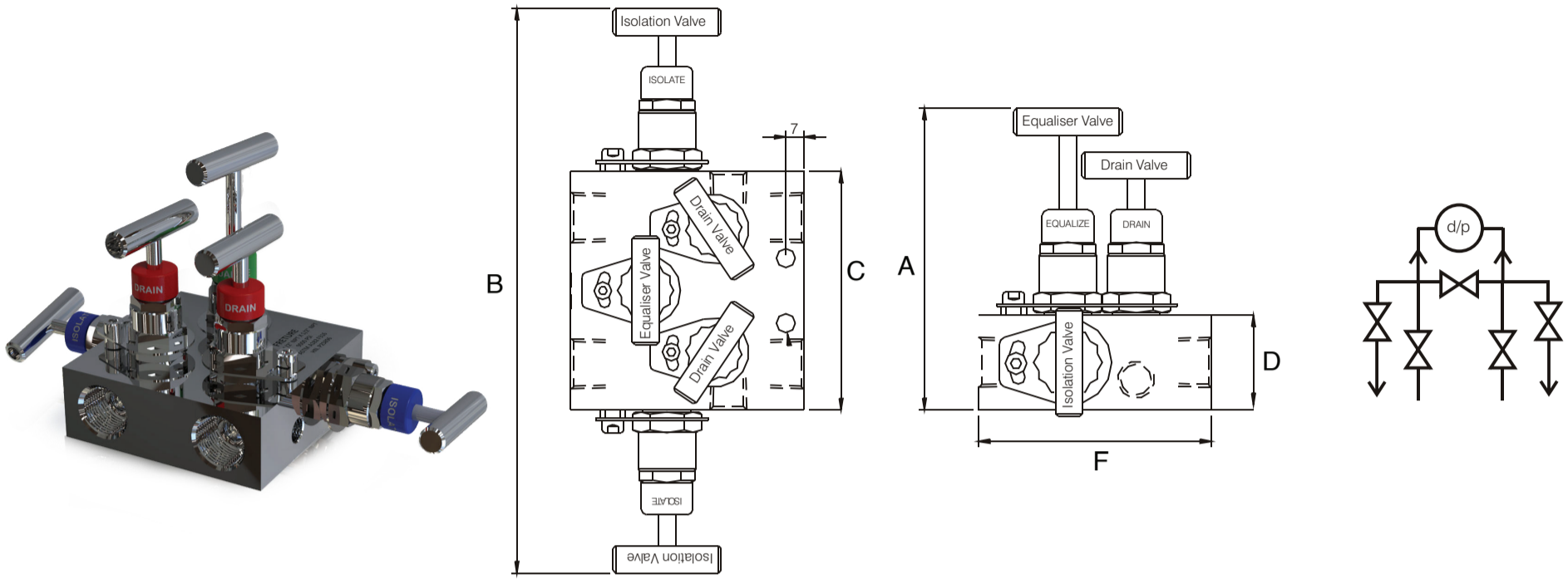

Pressure	Inlet	Outlet	Drain Port	A	B	C	D	E	F
6,000	1/2" F	1/2" F	1/4" F	150.2	216.4	75	29.8	155.2	88

## 5 Valve Manifold Coplanar

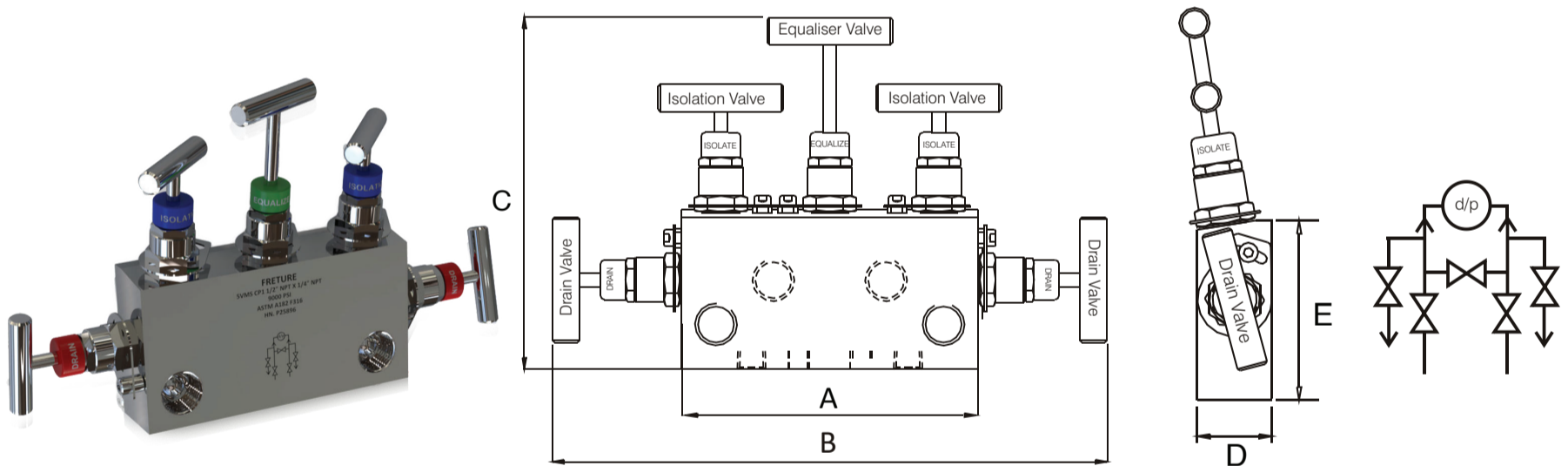

Pressure	Inlet	Outlet	Drain Port	A	B	C	D	E
6,000	1/2" F	1/2" F	1/4" F	140	230.4	155.2	29.5	70.2

## 5 Valve Manifold - T Type

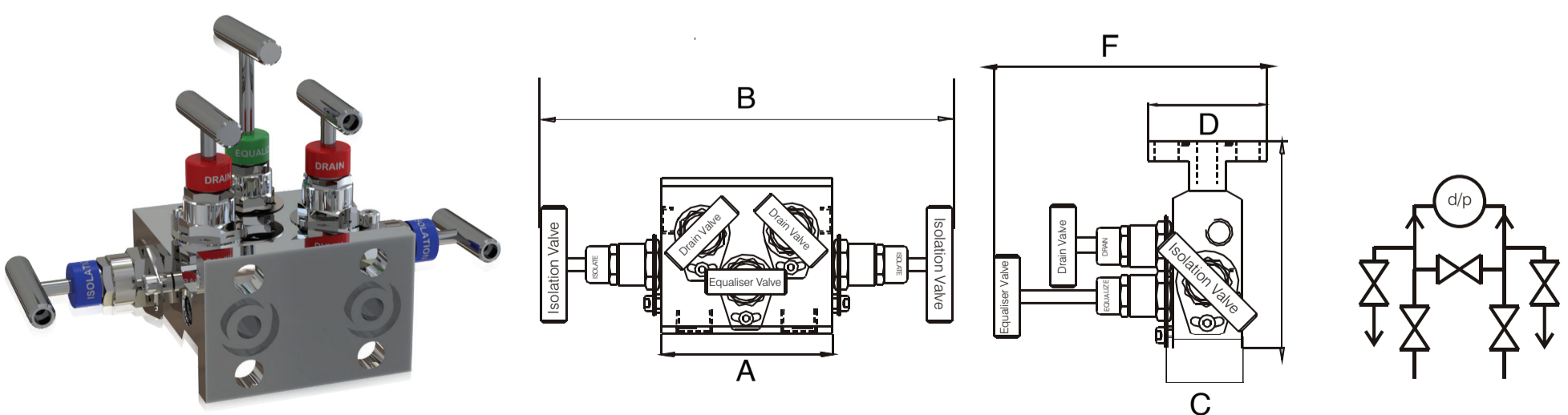

Pressure	Inlet	Outlet	Drain Port	A	B	C	D	E	F
6,000	1/2" F	1/2" F	1/4" F	91.2	210	35.4	62.5	109	116

## 5 Valve Manifold - H TYPE

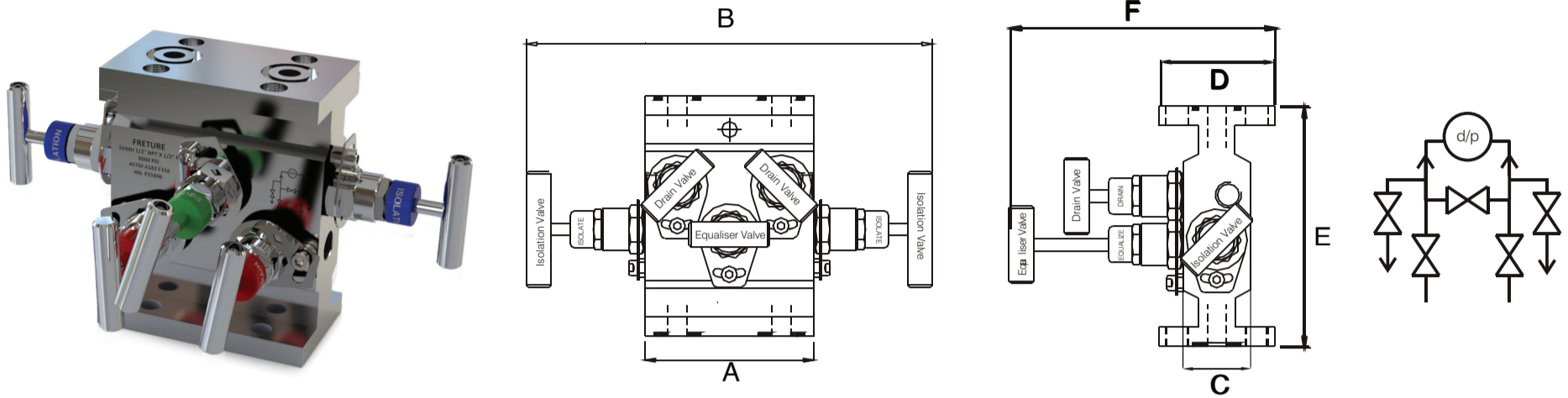

Pressure	Inlet	Outlet	Drain Port	A (mm)	B (mm)	C (mm)	D (mm)	E (mm)	F (mm)
6,000	1/2" F	1/2" F	1/4" F	91.2	210	35.4	62.5	120	110



# FRETURE

EMISSION FREE PROCESS

## PROCESS AUTOMATION & CONTROL

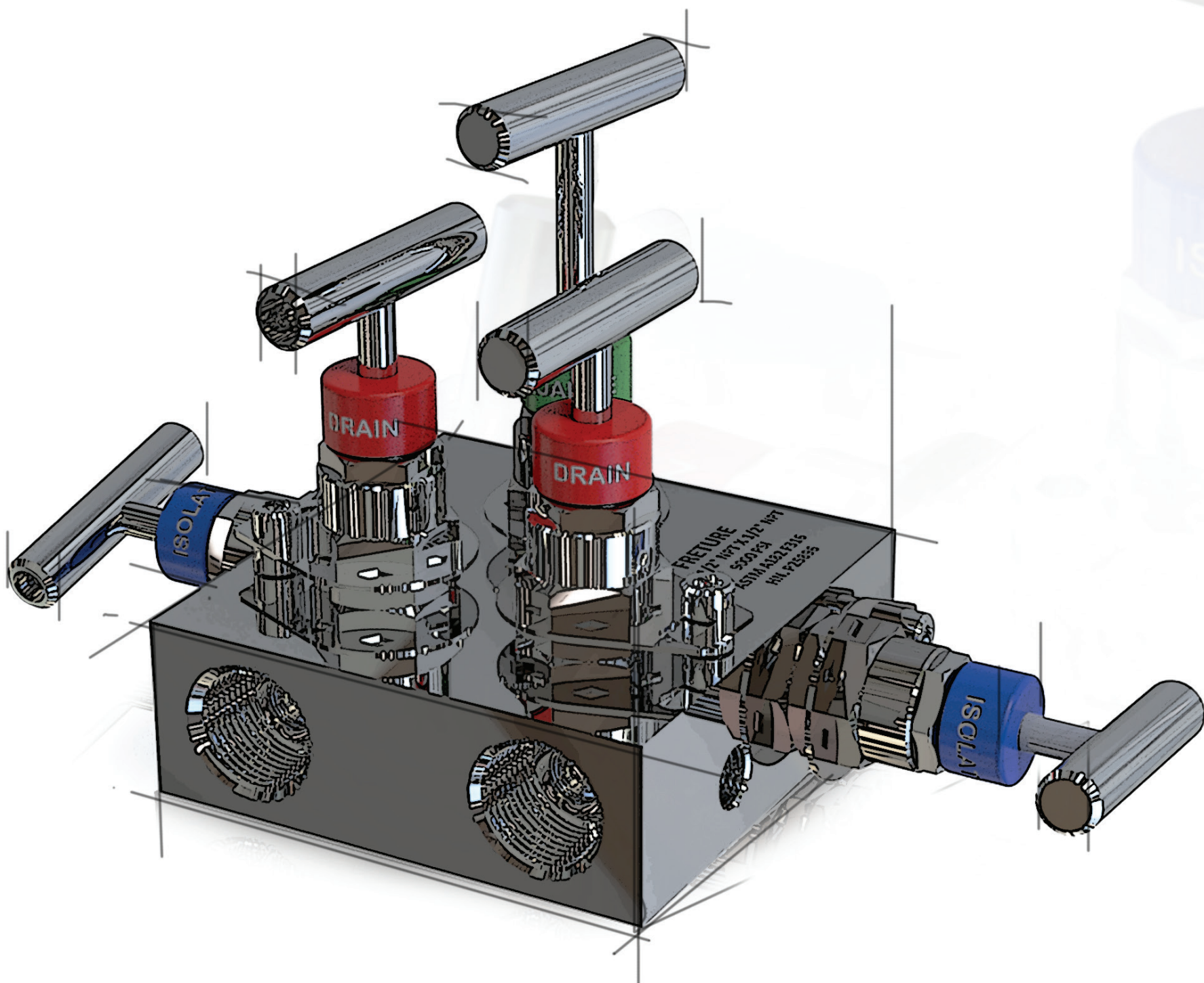

INNOVATION FOR SUSTAINABILITY

## TUBE FITTINGS

[www.freture.com](http://www.freture.com)

ISO 9001 - 15000 | ISO 14000 | ISO 45001 | PED 2014 / 68 / EU



# FRETURE

EMISSION FREE PROCESS

## CLIENTELE



# FRETURE TECHNO PVT. LTD.



Alpack Comp, Milind Nagar  
Bhandup (W) Mumbai 400 078



[www.freture.com](http://www.freture.com)



+91 75066 82777



[sales@freture.com](mailto:sales@freture.com)