

FRETURE

EMISSION FREE PROCESS

PROCESS AUTOMATION & CONTROL

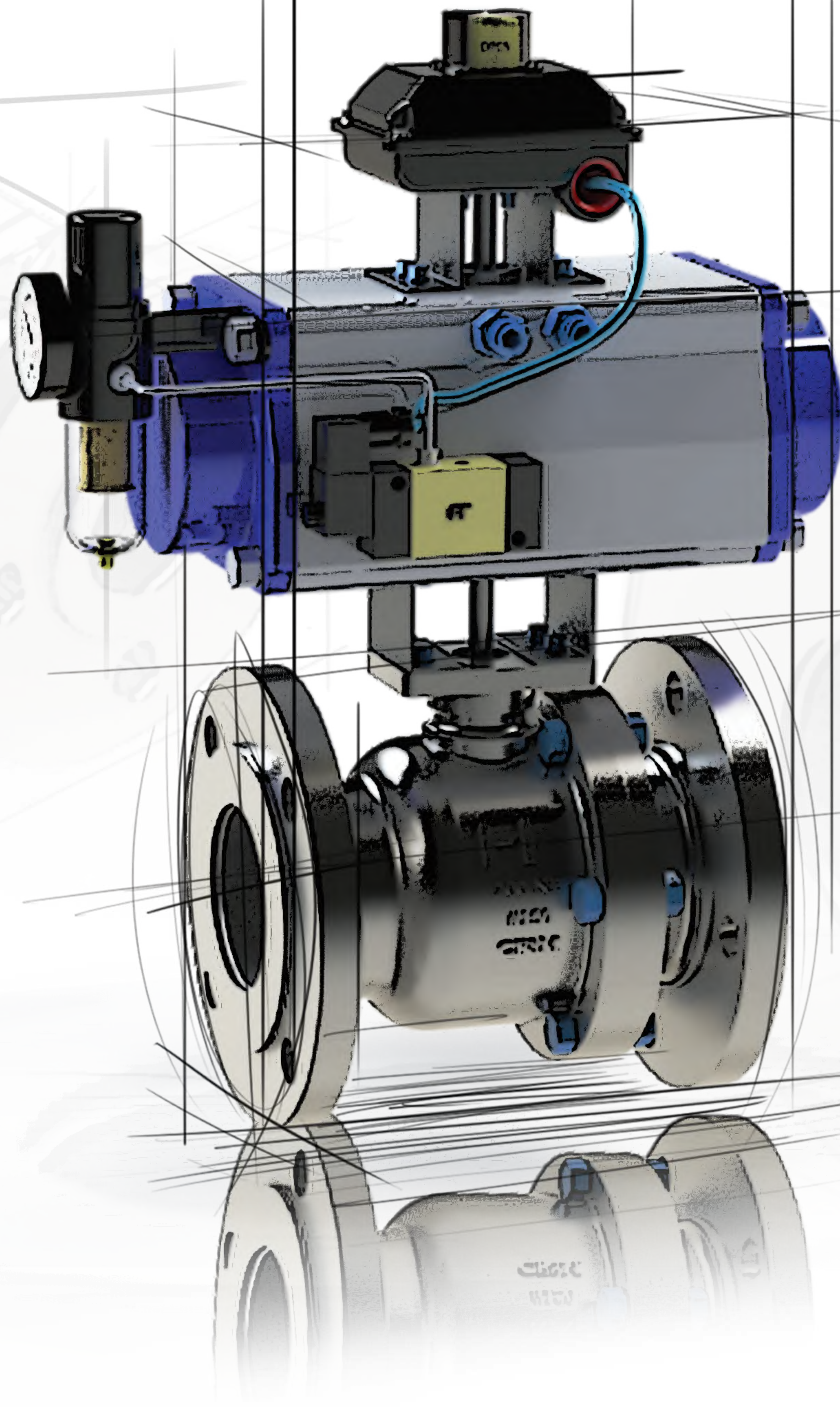

INNOVATION FOR SUSTAINABILITY

BALL VALVE

www.freture.com

ISO 9001 - 15000 | ISO 14000 | ISO 45001 | PED 2014 / 68 / EU

ABOUT US

Freture Techno, a prominent precision valve manufacturer with 15 years of experience, prioritizes excellence in every aspect of their work. Our valves, crafted by skilled professionals by taking Sustainability in a central theme, as they strive to minimize environmental impact through efficient manufacturing, ensuring exceptional products while reducing resource consumption and waste.

With a diverse clientele spanning Oil, Gas, pharmaceuticals, chemicals, petrochemicals, and food industries, Freture Techno exhibits versatility and adaptability to dynamic sector needs. As the company continues to innovate, they remain committed to providing sustainable Valve & Piping solutions that align with the evolving demands of clients globally.

VISION

Our vision is clear to provide precision products and services that enhance and strengthen relationships with our clients. We aspire to be the leading provider of valve solutions, renowned for our unwavering commitment to quality, reliability, and customer satisfaction.

Our vision is not just about delivering products; it's about fostering trust, reliability, and mutual growth in every interaction.

MISSION

At Freture Techno, our mission is to serve our precision products and services on a global scale, supporting industries in maintaining their critical flow processes. We are dedicated to providing innovative valve solutions that optimize efficiency and sustainability for our customers worldwide.

We ensure that every client, regardless of location or industry, can count on Freture Techno to deliver the products and support they need to thrive.

ABOUT BALL VALVE

A ball valve is made up of a valve body and a big sphere with a centre hole corresponding to the inside diameter of the pipe. As the ball rotates, the valve offers the through conduit or full bore required for unrestricted passage of the fluid and scrapers or pigs in the fully open position. In comparison to a gate valve, a ball valve has extremely little flow resistance when fully open. A ball valve's L/D ratio is around 3.0 when fully open. The ball valve, like the gate valve, is usually employed in either the completely open or fully closed state.

Unlike a gate valve, a ball valve requires only a quarter turn of the hand wheel to go from fully open to fully closed. Such rapid opening and closing of a ball valve may be important in some installations where swiftly isolating pipe sections is required in the event of an emergency.

The ball valve is a low-cost alternative to various types of valves. To control flow, ball valves use a metal ball with a hole punched through the centre situated between two seats. Ball valves, which are used in many hydrocarbon process applications, are capable of throttling gases and vapours and are especially effective in low flow settings. These valves open quickly and produce a very tight seal on difficult-to-hold fluids.

Full-Bore (FB) or Reduced Bore (RB) ball valves are available. The internal flow passage of an FB (also known as full port) valve is equal to the entire area of the input port. The flow area of the port (closure member) of an RB valve is less than the area of the inside diameter of the pipe and the inlet of the valve. The ball in a ball valve, also known as the obturator in some international valve standards, is referred to as the closure member. The usage of a pipeline injected gadget (PIG) in the pipeline is enabled via an FB valve. A PIG is developed and installed in the pipeline for inspection or cleaning purposes, such as removing wax or scale build-up.

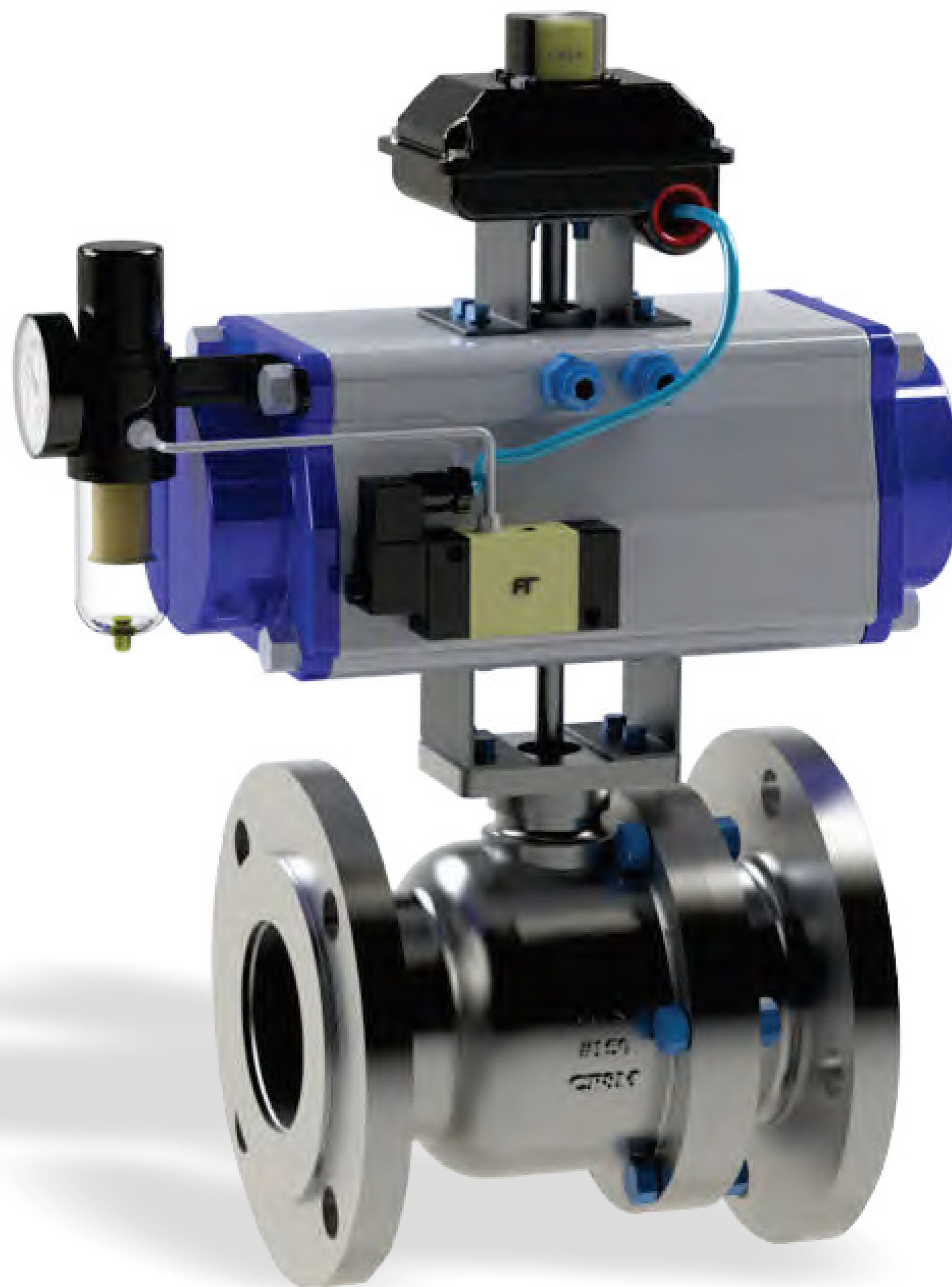

FEATURES OF BALL VALVE

A Ball is a very common & important type of valve, Isolate & Regulate the flow. Ball valves can be automatically operated with pneumatic and electric actuators to accomplish industrial automation in a variety of sectors. The ball valve can also be controlled manually at the same time. Fretures makes Ball valves in all types, all connections, all sizes, and all materials with the following features to suit your project needs and ensure the smooth operation of your project.

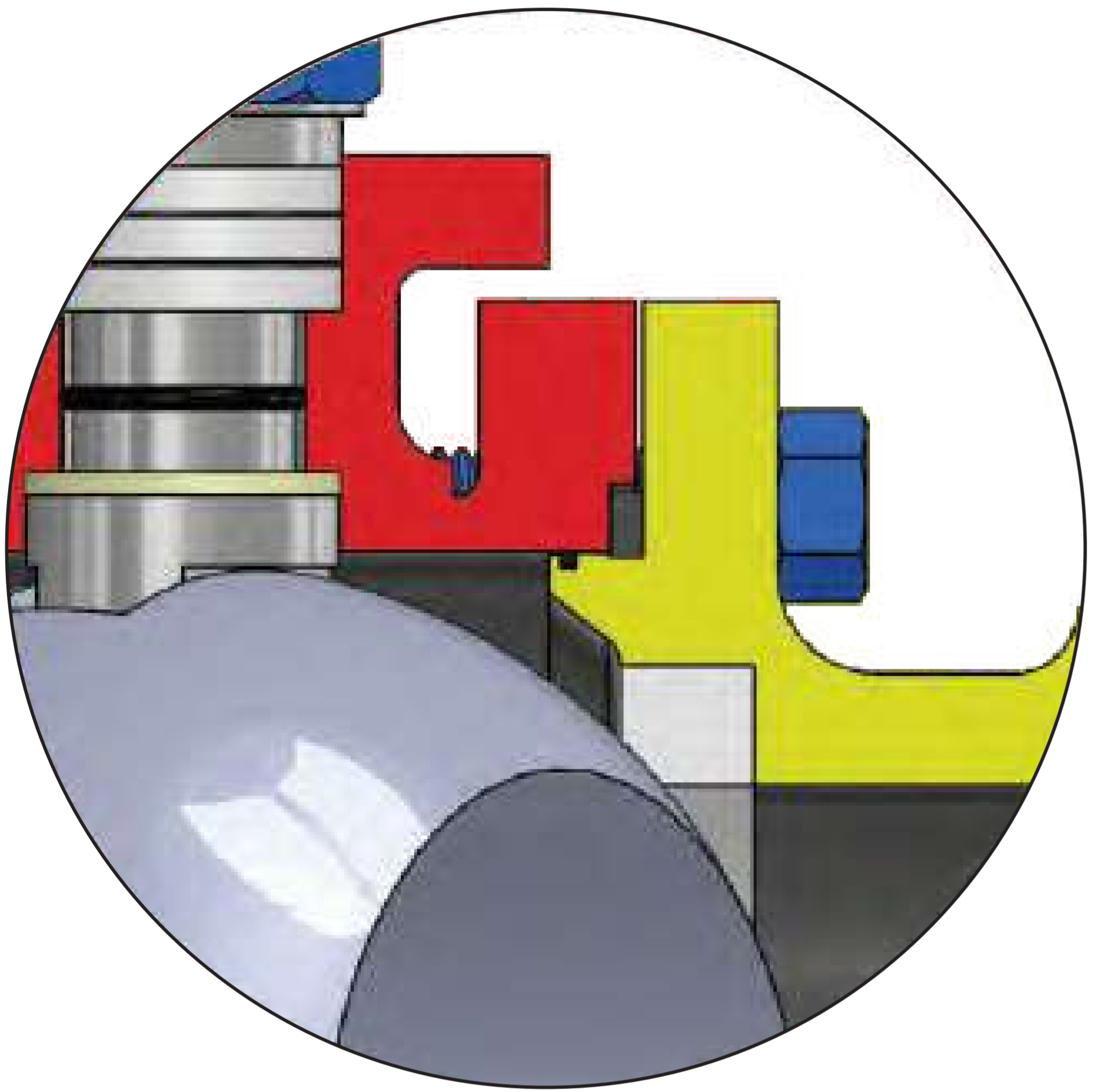

Firesafe

Fire- Safe Secondary metal seats are used in Ball Valves. In the event of a fire, the ball moves and abuts the downstream metal seat to produce a leak - tight seal after the soft seat completely sublimates.

Ball Valves are designed to be fire-safe and comply with API 6FA, API 607, and ISO 10497.

Blowout- Proof Stem

The ball valve has an integrated profile that stems a matching profile in the body to prevent blowouts. During an emergency, this capability also allows for the online replacement of packing rings.

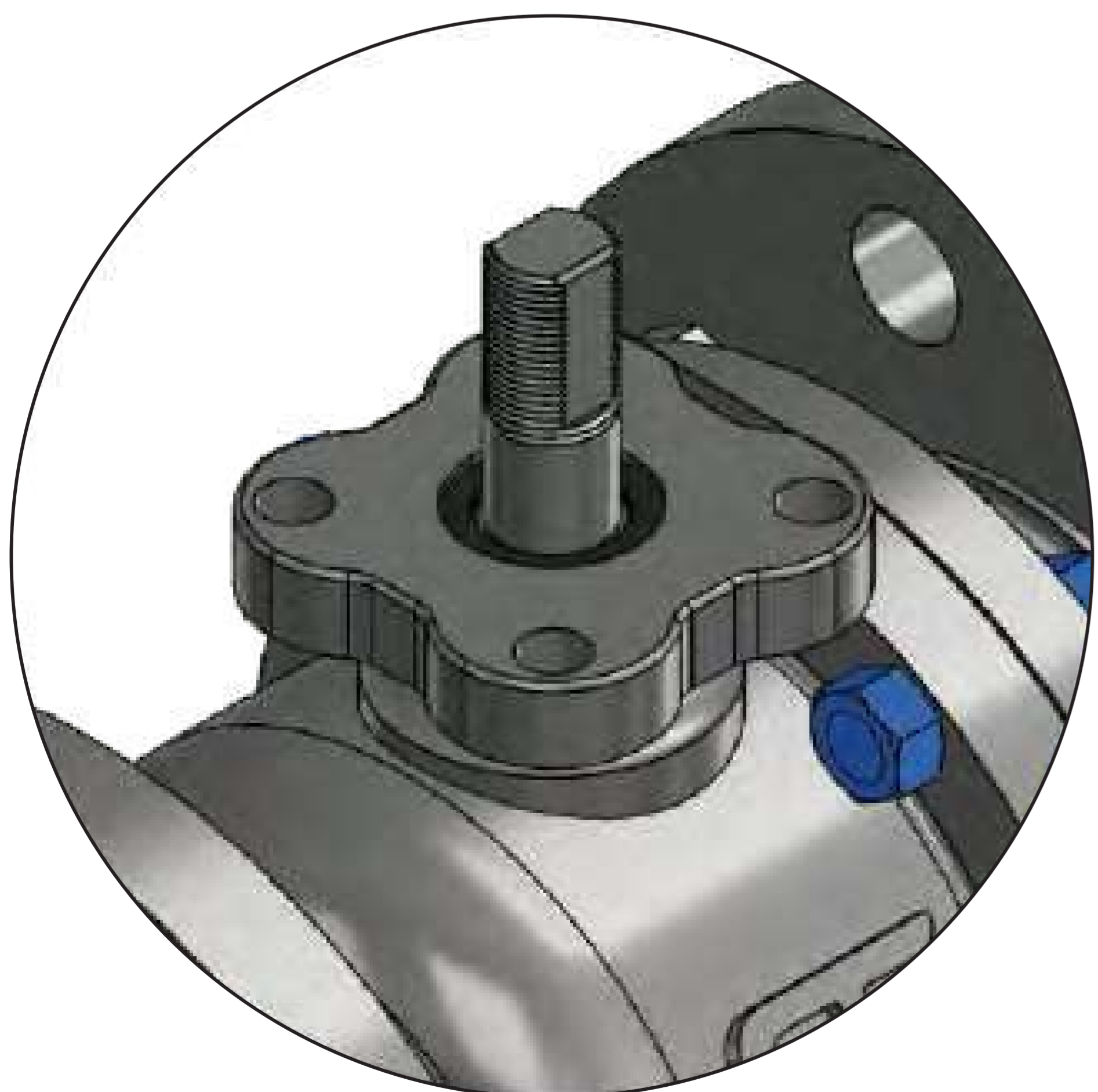
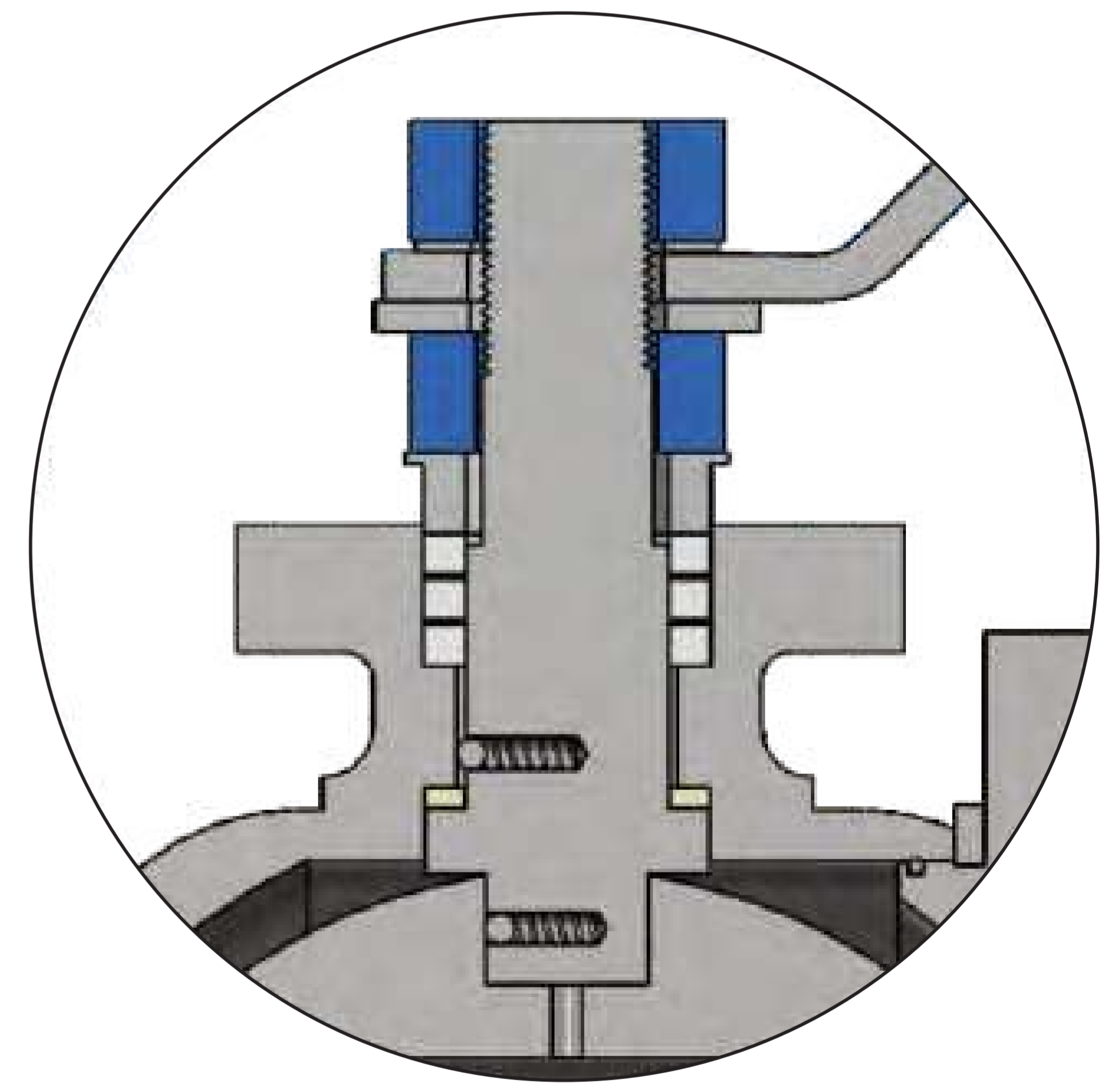

Iso Mounting Flange

One / two Piece Ball Valves have an incorporated actuator attachment flange that complies with ISO 5211.

Cavity Relief

All Ball Valves include an automatic cavity pressure release system to protect valve seats and balls from damage caused by over-pressurisation inside the cavity. When the entrapped fluid pressure surpasses 1.3 times the rated pressure, the spring-loaded seat is pulled away from the ball to alleviate pressure.

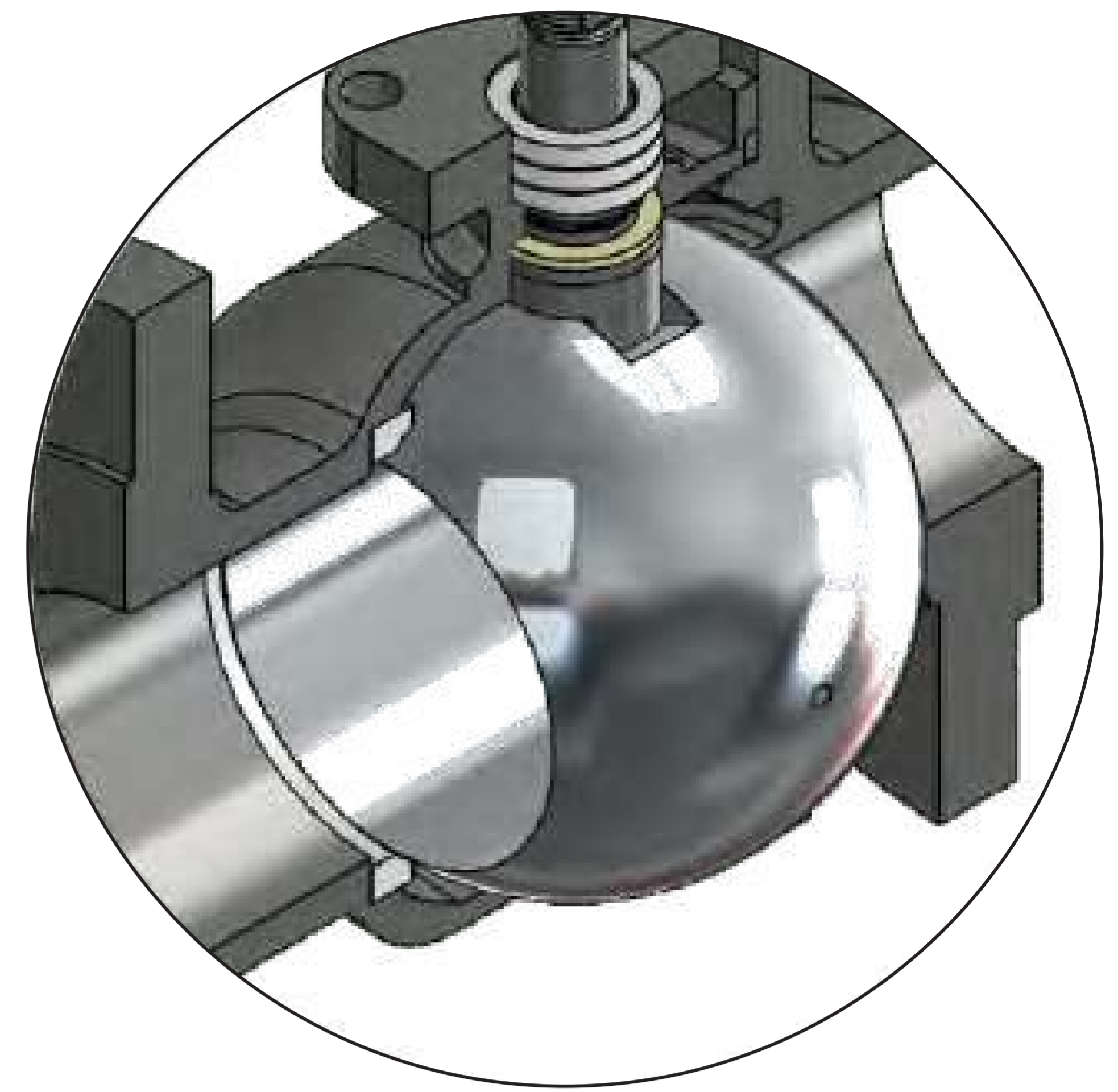

Mirror-finished Balls Made Of Solid Stainless Steel

Mirror-finished SS balls are utilized as a standard to achieve bubble-tight sealing and lower operating torques. The balls' robust structure ensures greater structural strength

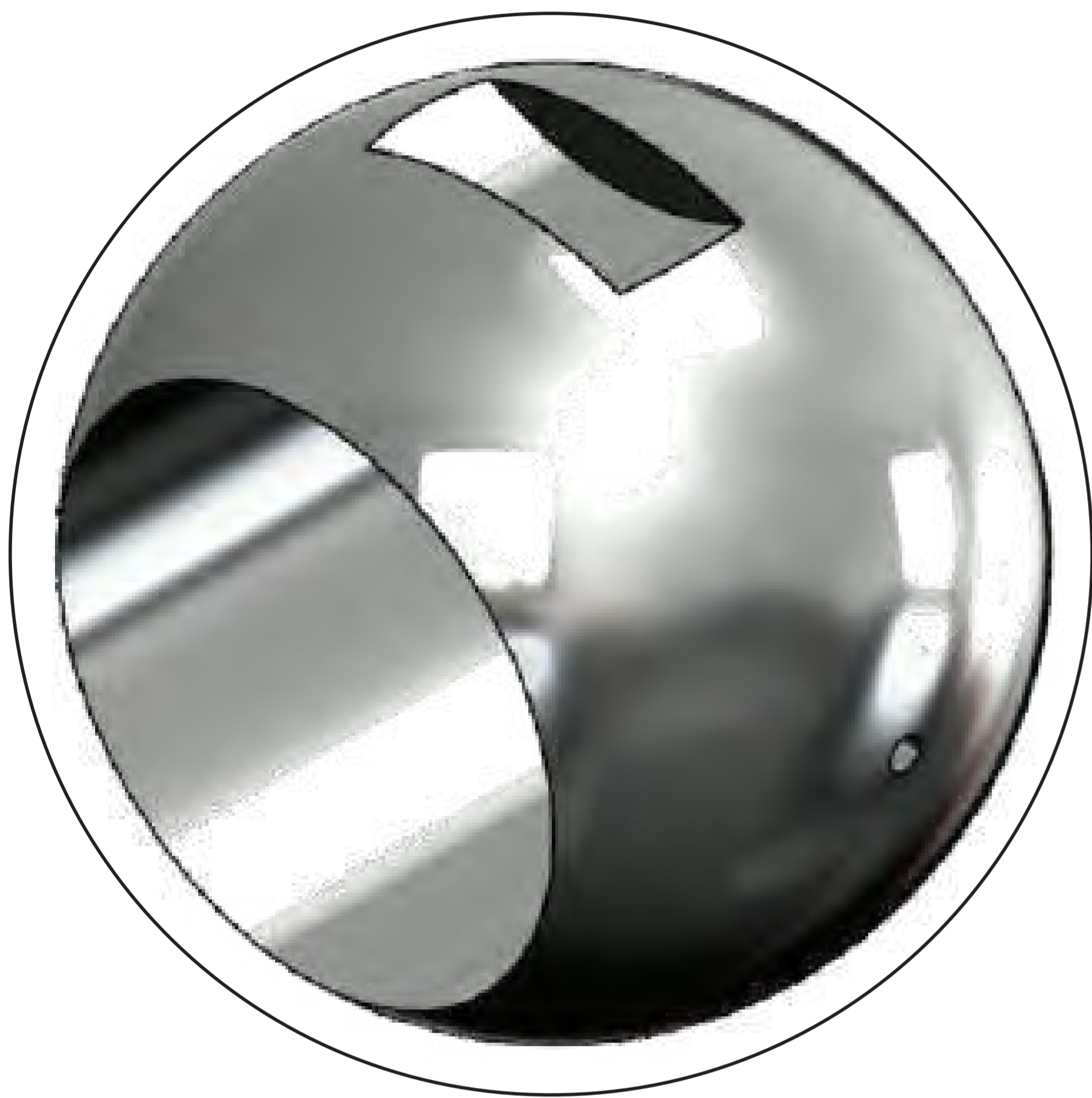

Anti-Static

The accumulation of static electricity caused by friction between the ball and the soft seat material is a fire danger. On the stem, a spring-loaded plunger ensures electrical continuity and dissipates any static energy generated.

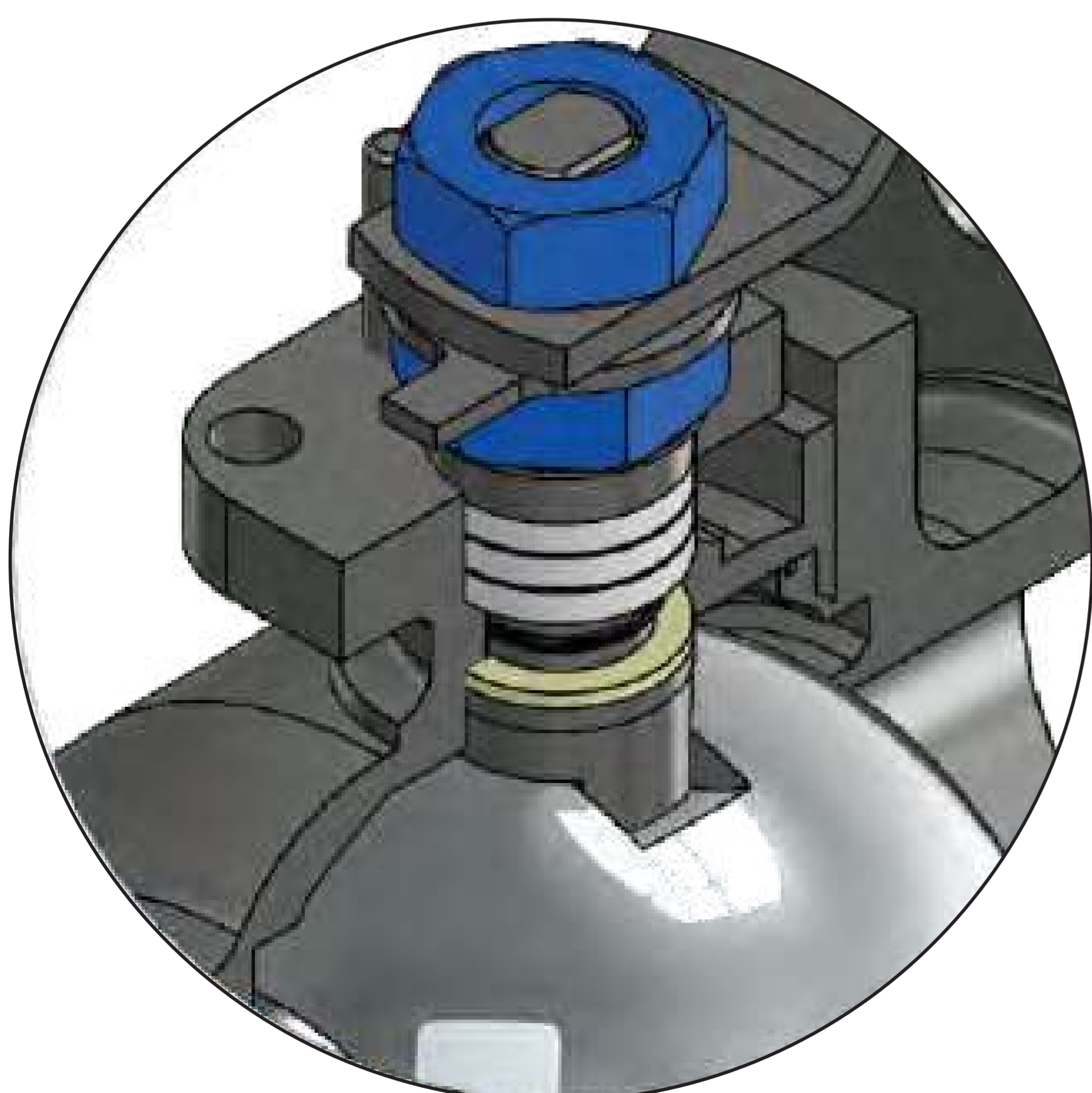
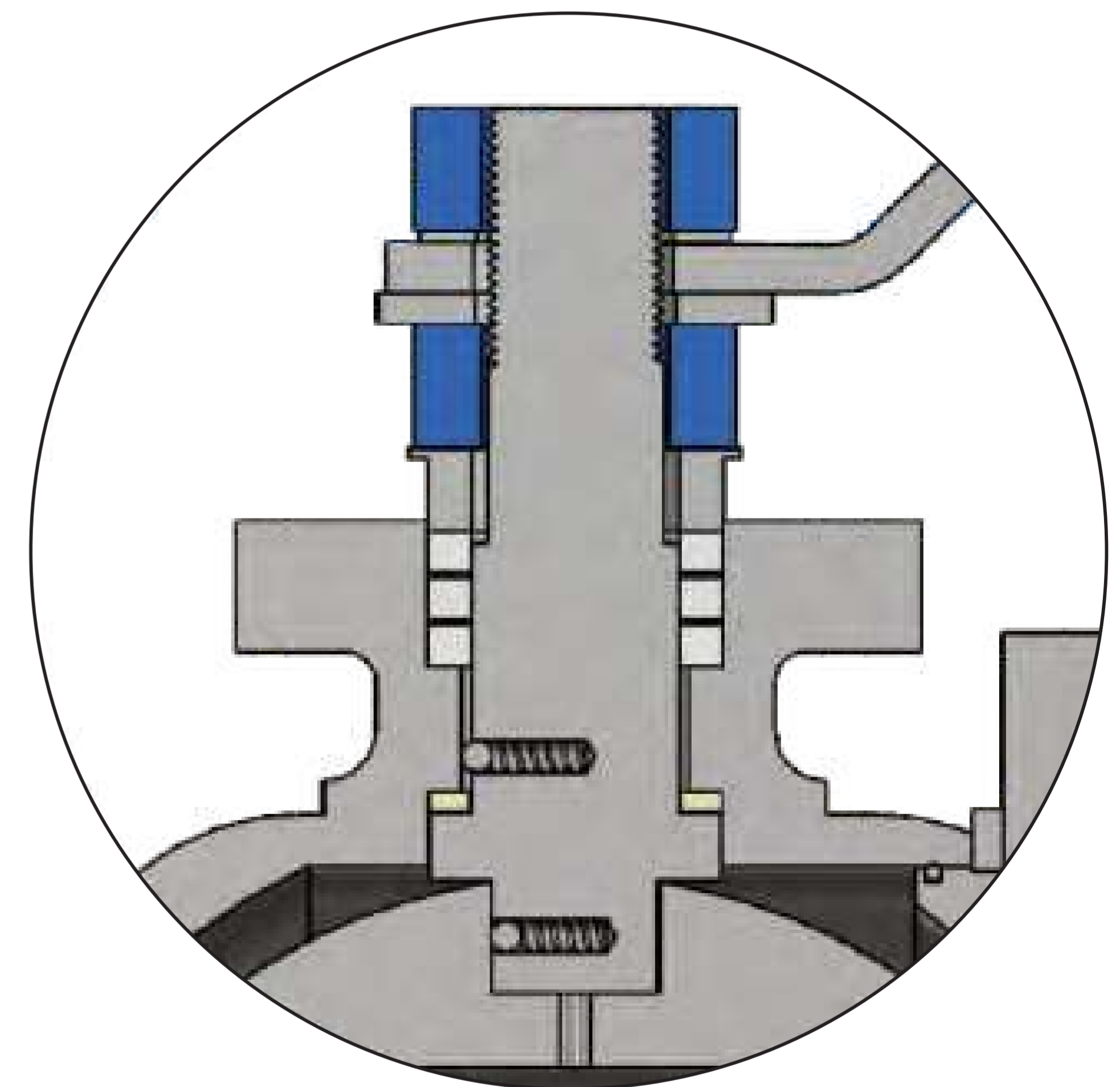

Stem Sealing With High Integrity

Stem thrust seals and stem packing rings improve the seal to the atmosphere even more. Belleville springs are used to compensate for wear and thermal expansions.

FLOATING BALL VALVE

In a floating ball valve, the ball is held in the position by the compression of the two elastomeric seats against the ball. The ball is free to float inside the valve body. The stem is connected to a slot at the top of the ball which allows the ball to rotate a quarter turn (90 degrees). The shaft allows for a certain amount of lateral movement of the ball that is generated from the upstream pressure acting on the ball.



SPECIFICATIONS	
Type	One Piece / Two Piece / Three Piece
Design Standard	API 6D rev 23; ISO 17292 rev 2004
Size	15 NB - 300 NB
Pressure Rating	#150 - #600
End Connection	Flange / Butt Weld
Fire-Safe Design	API-607 Rev 2010
Temp. Rating	7Deg C to 280 Deg
Testing	API 598 Rev 2009
Operation	Manual / Actuated / Gear Operated
MOC	Stainless Steel / Carbon Steel / Alloys
Documents	BS/EN 10204-3.1 REV 2004

NPS	DN	#150 Flange End Ball Valve			#300 Flange End Ball Valve		
		F - F (mm)	Cen. Ht. (mm)	Weight (kg)	F - F (mm)	Cen. Ht. (mm)	Weight (kg)
1/2	15	108	90	5	-	-	-
3/4	20	117	90	7	-	-	-
1	25	127	100	10	165	111	10
1 1/4	32	140	105	15	178	114	12
1 1/2	40	165	110	15	190	117	14
2	50	178	165	15	216	165	18
2 1/2	65	190	165	19	241	165	27
3	80	203	180	25	282	184	29
4	100	229	235	45	305	235	43
6	150	267	290	62	403	285	82
8	200	292	320	126	419	325	133
10	250	330	390	226	457	300	236
12	300	356	490	346	502	400	382

Note: Dimensions are according to Two Piece Lever Operated Ball Valve

TRUNNION MOUNTED BALL VALVE

Trunnion mounted valve is a solution to the problem of excessive torque required by a floating type valve in high-pressure service. A short shaft like an extension which is known as a trunnion set in the body. In this design stem and ball work as a single unit. The ball is supported by two floating or spring-loaded seats that remain in constant contact with the ball.



SPECIFICATIONS	
Type	Two Piece / Three Piece
Design Standard	API 6D rev 23; ISO 17292 rev 2004
Size	50mm - 300 mm
Pressure Rating	#150 - #1500
End Connection	Flange / Butt Weld
Fire-Safe Design	API-607 Rev 2010
Temp. Rating	(-)7Deg C to 280 Deg C
Testing	API 598 Rev 2009
Operation	Manual / Actuated / Gear Operated
MOC	Stainless Steel / Carbon Steel / Alloys
Documents	BS/EN 10204-3.1 REV 2004

NPS	DN	#150 Flange End Ball Valve			#300 Flange End Ball Valve		
		F - F (mm)	Cen. Ht. (mm)	Weight (kg)	F - F (mm)	Cen. Ht. (mm)	Weight (kg)
2	50	178	226	18	216	226	27
4	80	203	282	31	283	282	45
4	100	229	304	54	305	304	72
6	150	394	371	226	403	371	249
8	200	457	437	340	502	437	385
10	250	533	502	544	568	502	566
12	300	610	555	771	648	555	861

Note: Dimensions are according to 3 Piece Trunnion Mounted Ball Valve

3 WAY BALL VALVE

Depending on your requirements, you can arrange the port of valve in the three-way.

1. One inlet and two distribute
2. One inlet and one outlet with diverting a Flow
3. Straight pass the fluid without No Inlet

Three patterns are available. Venturi port type, full port type, and reduced port type. The full-port ball valve has an inside diameter equal to the inside diameter of the pipe. This design allows pigging. In the venturi and reduced-port types, the port is generally onepipe size smaller than the line size. The ball type disc can be a free float or fixed in the valve body.

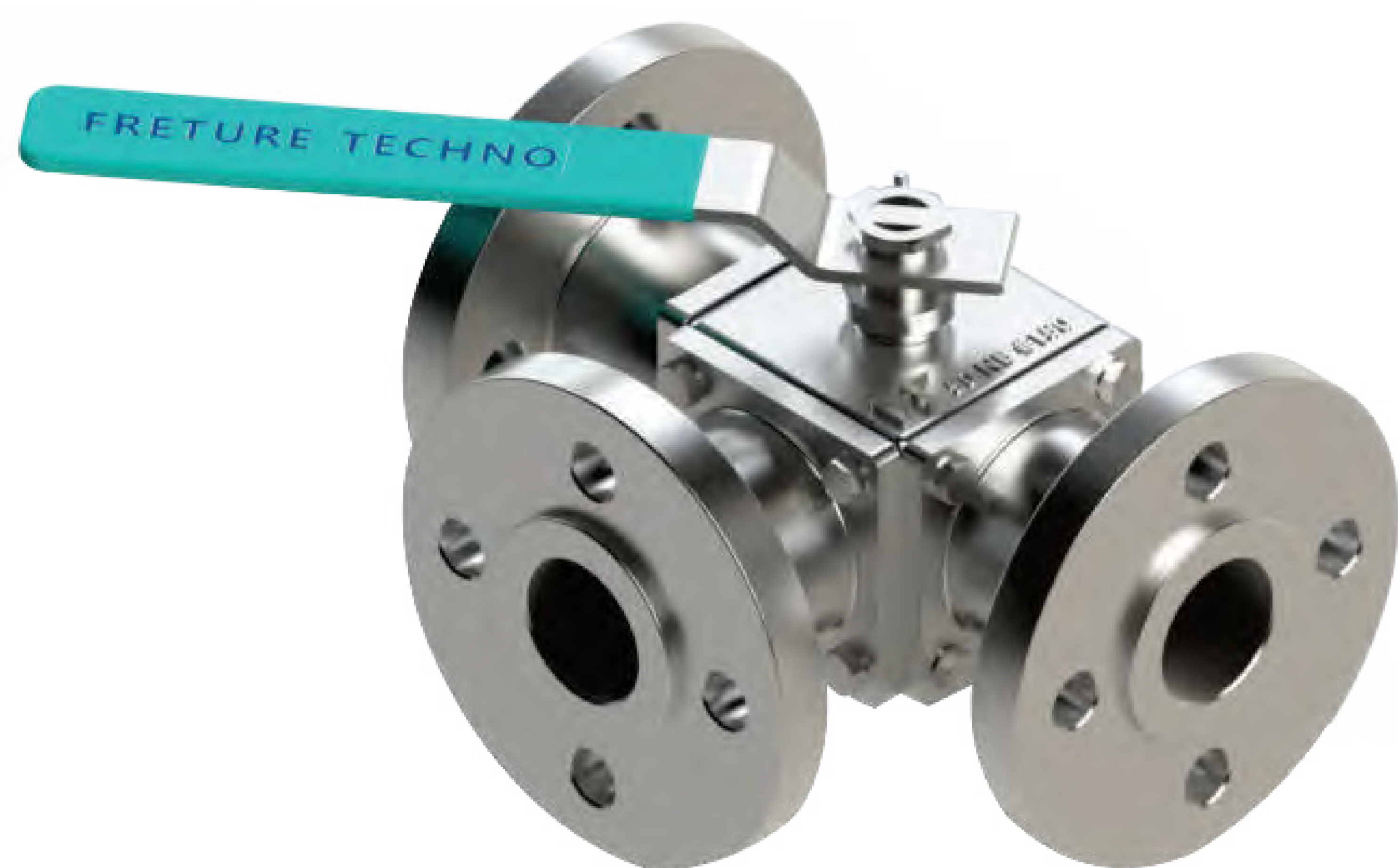

SPECIFICATIONS	
Type	3 way Ball Valve
Design Standard	API 6D rev 23; ISO 17292 rev 2004
Size	15mm to 100mm
Pressure Rating	ASME #150, PN 20, ASME #300, PN 50
End Connection	Flange
Fire-Safe Design	API-607 Rev 2010
Temp. Rating	35 Deg C to 280 Deg C (Soft Seated)
Testing	API 598 Rev 2009
Operation	Manual / Acturated / Gear Opreted
MOC	Stainless Steel / Carbon Steel / Alloys
Documents	BS/EN 10204-3.1 REV 2004

NPS	DN	#150 Flange End Ball Valve			#300 Flange End Ball Valve		
		F - F (mm)	Cen. Ht. (mm)	Weight (kg)	F - F (mm)	Cen. Ht. (mm)	Weight (kg)
1/2	15	108	90	7	-	-	-
3/4	20	117	90	10	-	-	-
1	25	127	100	14	165	111	14
1 1/4	32	140	105	21	178	114	17
1 1/2	40	165	110	21	190	117	20
2	50	178	165	21	216	165	25
2 1/2	65	190	165	27	241	165	38
3	80	203	180	35	282	184	41
4	100	229	235	63	305	235	60

FORGED BALL VALVE

Forged Ball Valve provides a comprehensive variety of high Performance Forged Steel Valves to supplement and complete the cast steel offering. Valves in ASME classes #800- #2500 are supplied with bolted body-bonnet joints; screwed joints are available for higher pressure classes. The valves are designed to withstand temperatures of up to 425 degrees Celsius in carbon steel and 540 degrees Celsius in alloy steel.



SPECIFICATIONS	
Type	Two Piece / Three Piece
Design Standard	ISO 17292 rev 2004 / BS 5351
Size	15 NB - 100
Pressure Rating	#800 - #2500
End Connection	Socket Weld / Screwed End
Fire-Safe Design	API 607 Rev 2010
Temp. Rating	7Deg C to 280 Deg C
Testing	API 598 Rev 2009
Operation	Manual / Actuated / Gear Operated
MOC	Stainless Steel / Carbon Steel / Alloys
Documents	BS/EN 10204-3.1 REV 2004

NPS	DN	#800		
		F - F (mm)	Cen. Ht. (mm)	Weight (kg)
1/2	15	66	50	1
3/4	20	75	58	1
1	25	92	65	2
1 1/4	32	114	83	4
1 1/2	40	114	83	4
2	50	132	94	6
2 1/2	65	185	200	15.5
3	80	208	225	25
4	100	240	250	39

Note: Screwed / Socket-weld valves in size DN 8 To DN 50 have a body rating of class 800.
In larger sizes, the body is rated to class 300.

LINED BALL VALVE

Lined Ball Valves are a type of ball valve which are made up of a body, stem, ball, seat and lining. They are also known as a Shut Off valve. The interior is completely lined with a high quality PTFE or PFA lining material and due to its thickness it completely protects the valves against any chemical corrosion which makes it an excellent choice for any nasty applications.



SPECIFICATIONS	
Type	One Piece / Two Piece / Three Piece
Design Standard	API 6D rev 23; ISO 17292 rev 2004
Size	15 NB - 300 NB
Pressure Rating	#150 - #600
End Connection	Flange / Butt Weld
Fire-Safe Design	API-607 Rev 2010
Temp. Rating	7Deg C to 280 Deg
Testing	API 598 Rev 2009
Operation	Manual / Actuated / Gear Operated
MOC	Stainless Steel / Carbon Steel / Alloys
Documents	BS/EN 10204-3.1 REV 2004

NPS	DN	#150 Flange End Ball Valve			#300 Flange End Ball Valve		
		F - F (mm)	Cen. Ht. (mm)	Weight (kg)	F - F (mm)	Cen. Ht. (mm)	Weight (kg)
1/2	15	108	90	5	-	-	-
3/4	20	117	90	7	-	-	-
1	25	127	100	10	165	111	10
1 1/4	32	140	105	15	178	114	12
1 1/2	40	165	110	15	190	117	14
2	50	178	165	15	216	165	18
2 1/2	65	190	165	19	241	165	27
3	80	203	180	25	282	184	29
4	100	229	235	45	305	235	43
6	150	267	290	62	403	285	82
8	200	292	320	126	419	325	133
10	250	330	390	226	457	300	236
12	300	356	490	346	502	400	382

Note: Dimensions are according to Two Piece Lever Operated Ball Valve.

JACKETED BALL VALVE

Full Jacketed Ball valves are designed in Single-Piece Welded Jacket construction for Standard Bore valves. The jacket extends from one flange to other which is generally oversized with face to face dimension of corresponding valve. The jacket comes in two-piece construction welded together.

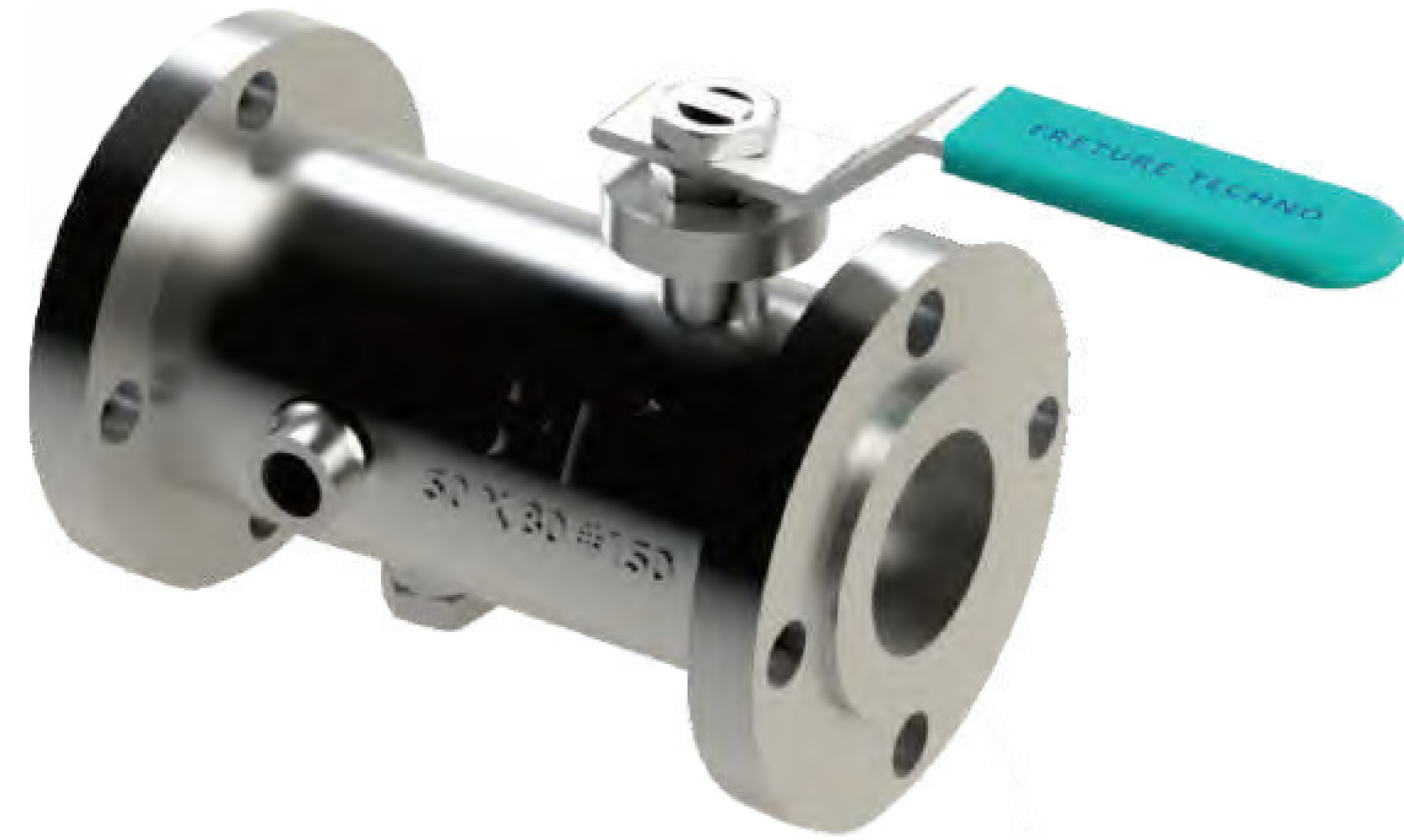

SPECIFICATIONS	
Type	Single Piece Flanged End Jacketed Ball Valve
Design Standard	API 6D rev 23; ISO 17292 rev 2004
Size	15 mm to 250mm
Pressure Rating	ASME #150, PN 20, ASME #300, PN 50
End Connection	Flange
Fire-Safe Design	API 607 Rev 2010
Temp. Rating	35 Deg C to 280 Deg C (Soft Seated)
Testing	API 598 Rev 2009
Operation	Manual / Actuated / Gear Operated
MOC	Stainless Steel / Carbon Steel / Alloys
Documents	BS/EN 10204-3.1 REV 2004

NPS	DN	#150 Flange End Ball Valve			#300 Flange End Ball Valve		
		F - F (mm)	Cen. Ht. (mm)	Weight (kg)	F - F (mm)	Cen. Ht. (mm)	Weight (kg)
1/2	15	108	90	5	-	-	-
3/4	20	117	90	7	-	-	-
1	25	127	100	10	165	111	10
1 1/4	32	140	105	15	178	114	12
1 1/2	40	165	110	15	190	117	14
2	50	178	165	15	216	165	18
2 1/2	65	190	165	19	241	165	27
3	80	203	180	25	282	184	29
4	100	229	235	45	305	235	43
6	150	267	290	62	403	285	82
8	200	292	320	126	419	325	133
10	250	330	390	226	457	300	236

Note: Dimensions are according to 2 piece ball valve

METAL SEATED BALL VALVE

Metal-seated ball valves incorporate a metal-to-metal seal between the seats and ball of the valve assembly. They are made for the severe service of abrasives, corrosives, high-temperature or high-pressure applications. Most metal-seated ball valves are typically used for isolation, but many are also used for uni- or bi-directional control as they offer tight shutoff in severe service applications.

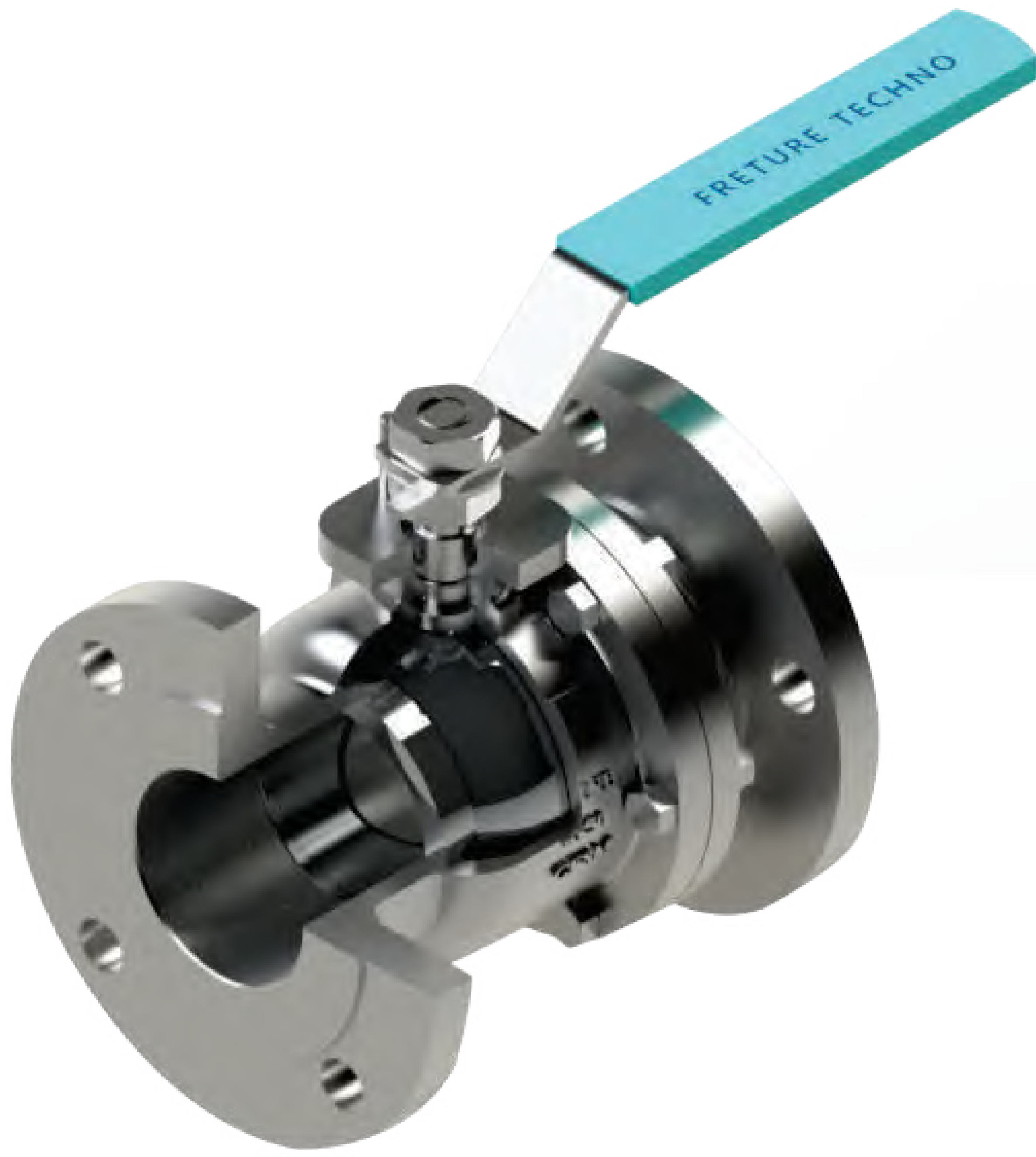

SPECIFICATIONS	
Type	Two Piece Flanged End
Design Standard	API 6D rev 23; ISO 17292 rev 2004
Size	15 mm to 250mm
Pressure Rating	ASME #150, PN 20, ASME #300, PN 50, ASME #600, PN 100
End Connection	Flange
Fire-Safe Design	API-607 Rev 2010
Temp. Rating	35 Deg C to 538 Deg C (Soft Seated)
Testing	API 598 Rev 2009
Operation	Manual / Actuated / Gear Operated
MOC	Stainless Steel / Carbon Steel / Alloys
Documents	BS/EN 10204-3.1 REV 2004

NPS	DN	#150 Flange End Ball Valve			#300 Flange End Ball Valve		
		F - F (mm)	Cen. Ht. (mm)	Weight (kg)	F - F (mm)	Cen. Ht. (mm)	Weight (kg)
1/2	15	108	90	5	-	-	-
3/4	20	117	90	7	-	-	-
1	25	127	100	10	165	111	10
1 1/4	32	140	105	15	178	114	12
1 1/2	40	165	110	15	190	117	14
2	50	178	165	15	216	165	18
2 1/2	65	190	165	19	241	165	27
3	80	203	180	25	282	184	29
4	100	229	235	45	305	235	43
6	150	267	290	62	403	285	82
8	200	292	320	126	419	325	133
10	250	330	390	226	457	300	236

Note: Dimensions are according to 2 piece ball valve

CAVITY FILLER BALL VALVE

Cavity filled ball-valves have special seat design that fills the gap around the ball, eliminating possibility of contamination buildup over time, offering excellent performances in pharmaceutical, food and beverage, micro brewing, process gas and other sanitary systems.

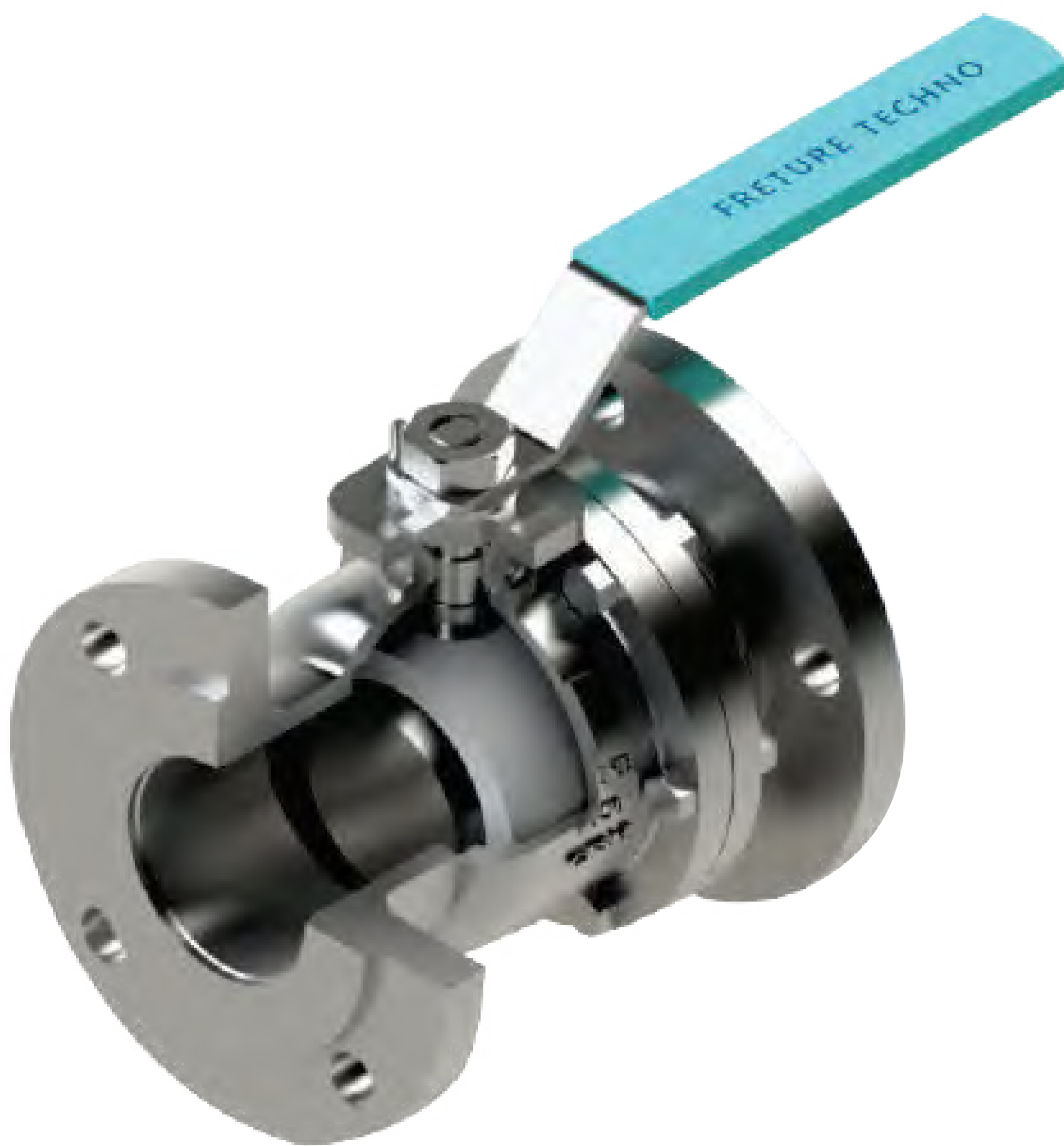

SPECIFICATIONS	
Type	Two Piece Zero Cavity Ball Valve
Design Standard	API 6D rev 23; ISO 17292 rev 2004
Size	15 mm to 200mm
Pressure Rating	ASME #150, PN 20, ASME #300, PN 50, ASME #600, PN 100
End Connection	Flange
Fire-Safe Design	API-607 Rev 2010
Temp. Rating	35 Deg C to 538 Deg C (Soft Seated)
Testing	API 598 Rev 2009
Operation	Manual / Actuated / Gear Operated
MOC	Stainless Steel / Carbon Steel / Alloys
Documents	BS/EN 10204-3.1 REV 2004

NPS	DN	#150 Flange End Ball Valve			#300 Flange End Ball Valve		
		F - F (mm)	Cen. Ht. (mm)	Weight (kg)	F - F (mm)	Cen. Ht. (mm)	Weight (kg)
1/2	15	108	90	5	-	-	-
3/4	20	117	90	7	-	-	-
1	25	127	100	10	165	111	10
1 1/4	32	140	105	15	178	114	12
1 1/2	40	165	110	15	190	117	14
2	50	178	165	15	216	165	18
2 1/2	65	190	165	19	241	165	27
3	80	203	180	25	282	184	29
4	100	229	235	45	305	235	43
6	150	267	290	62	403	285	82
8	200	292	320	126	419	325	133

Note: Dimensions are according to 2 piece ball valve

WAFER TYPE BALL VALVE

Wafer Type Ball Valve Compact, flange less ball valves that keep process control costs low, the envelope small and installation simple wafer ball valves are designed for process systems where lightweight, compact envelope size and ease of installation and repair are important considerations.

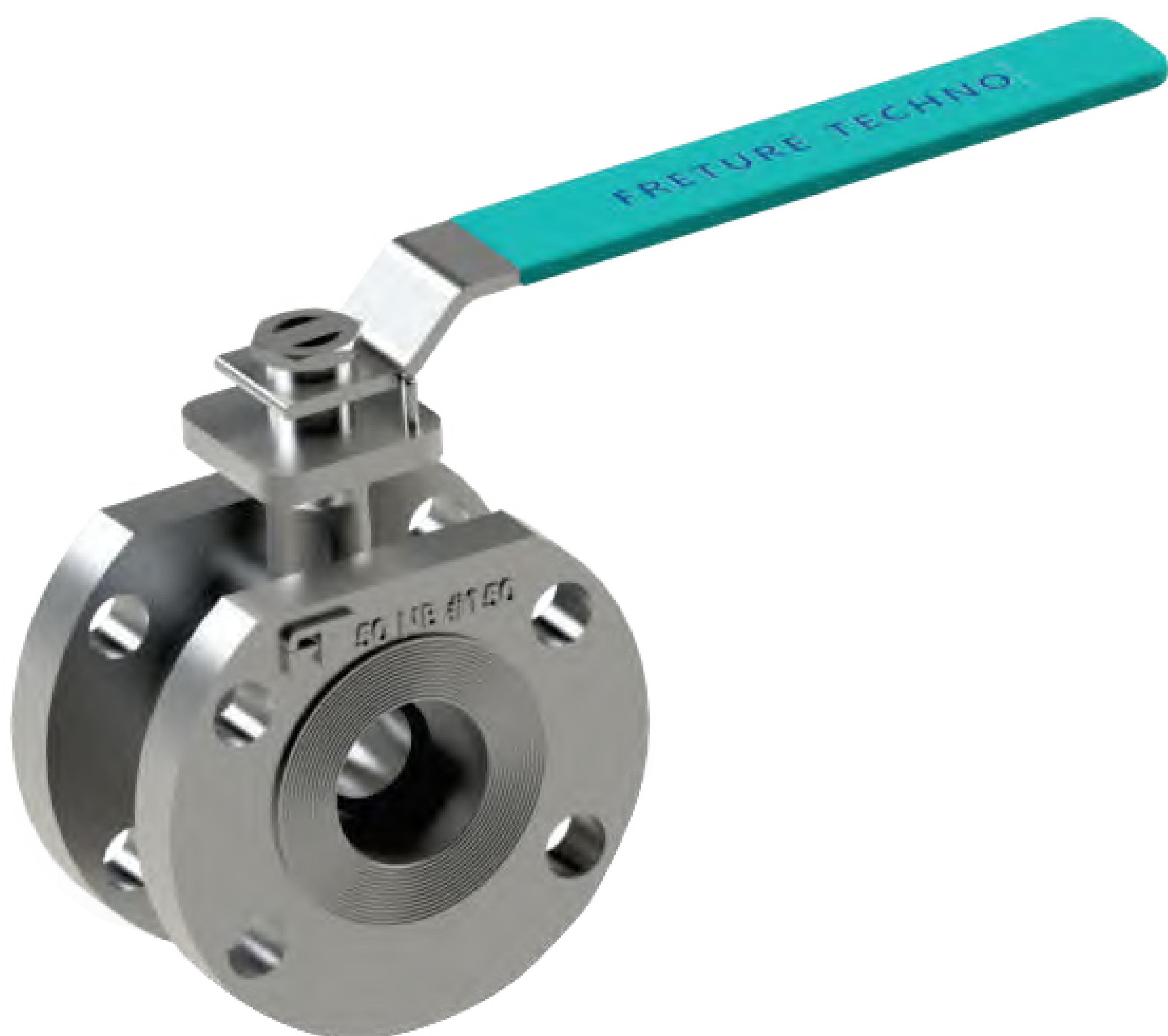

SPECIFICATIONS	
Type	Single Piece Wafer Type
Design Standard	API 6D rev 23; ISO 17292 rev 2004
Size	15 mm to 100mm
Pressure Rating	ASME #150, PN 20, ASME #300, PN 50, ASME #600, PN 100
End Connection	Flange
Fire-Safe Design	API-607 Rev 2010
Temp. Rating	35 Deg C to 538 Deg C (Soft Seated)
Testing	API 598 Rev 2009
Operation	Manual / Actuated / Gear Operated
MOC	Stainless Steel / Carbon Steel / Alloys
Documents	BS/EN 10204-3.1 REV 2004

NPS	DN	#150		
		F - F (mm)	Cen. Ht. (mm)	Weight (kg)
1/2	15	35	102	1.6
3/4	20	35	102	1.9
1	25	43	106	2.7
1 1/4	32	51	115	5.3
1 1/2	40	64	129	5
2	50	85	137	7.4
2 1/2	65	103	150	10.3
3	80	120	185	14.4
4	100	155	200	21.8

Note: DIN DN65 and DN100 only available PN16.

FRETURE

EMISSION FREE PROCESS

CLIENTELE

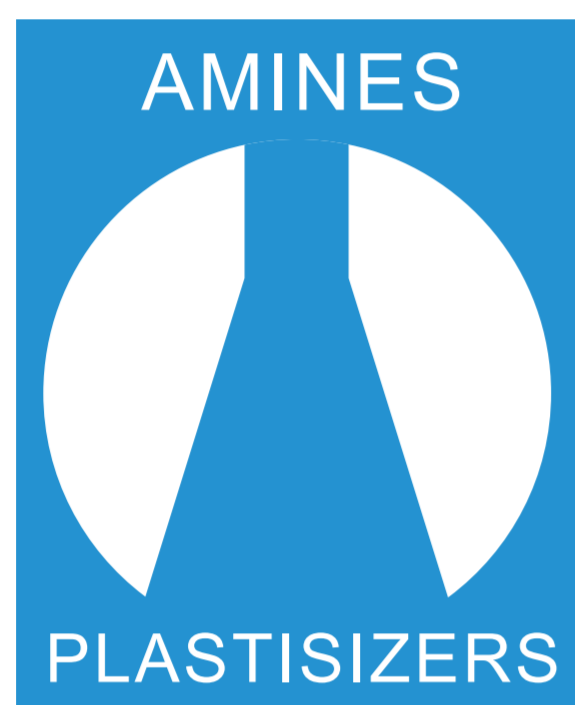

FRETURE TECHNO PVT. LTD.

 Alpack Comp, Milind Nagar
Bhandup (W) Mumbai 400 078

 www.freture.com
 +91 75066 82777
 sales@freture.com